



DICOM Conformance Statement

CR-IR 358CL

(Media Storage)

July, 2007

1st Edition

Copyright FUJIFILM Corporation, Japan

Revision History

History	Date	Revision Description
1st Edition	July, 2007	

CONTENTS

1. Introduction	3
2. Implementation Mode	3
2.1 Data Flow Diagram	3
2.2 Functional Definitions of Application Entities	4
2.3 Sequencing of Real World Activities	4
2.4 File Meta Information for Implementation Class and Version	4
3. AE Specification	5
3.1 CR-IR 358CL AE Specification	5
3.1.1 File Meta Information for Application Entity	5
3.1.2 Real World Activities	5
3.1.2.1 Real World Activity: Create	5
3.1.2.1.1 Application Profile: Create	5
3.1.2.2 Real World Activity: Display Directory	5
3.1.2.2.1 Application Profile: Display Directory	5
3.1.2.3 Real World Activity: Update	6
3.1.2.3.1 Application Profile: Update	6
3.2 SOP Classes and Transfer Syntaxes	6
4. Augmented Profiles	7
5. Extensions, Specializations, Privatizations of SOP Classes and Transfer Syntaxes	7
6. Configuration	7
7. Support of Extended Character Sets	7
8. Media Storage Directory IOD Overview	8
8.1 Module Table	8
8.1.1 File-set Identification Module	8
8.1.2 Directory Information Module	9
8.2 Relationship Between Directory Records	11
8.2.1 Patient Directory Record Definition	11
8.2.2 Study Directory Record Definition	12
8.2.3 Series Directory Record Definition	12
8.2.4 Image Directory Record Definition	12

1. Introduction

This document provides the DICOM conformance statement of the DICOM media interchange for the CR-IR 358CL.

2. Implementation Mode

Provided with an auxiliary storage device that includes USB flash drive and software used for such device, the CR-IR 358CL writes, reads and updates DICOM SOP instance on a medium determined for the auxiliary storage device.

2.1 Data Flow Diagram

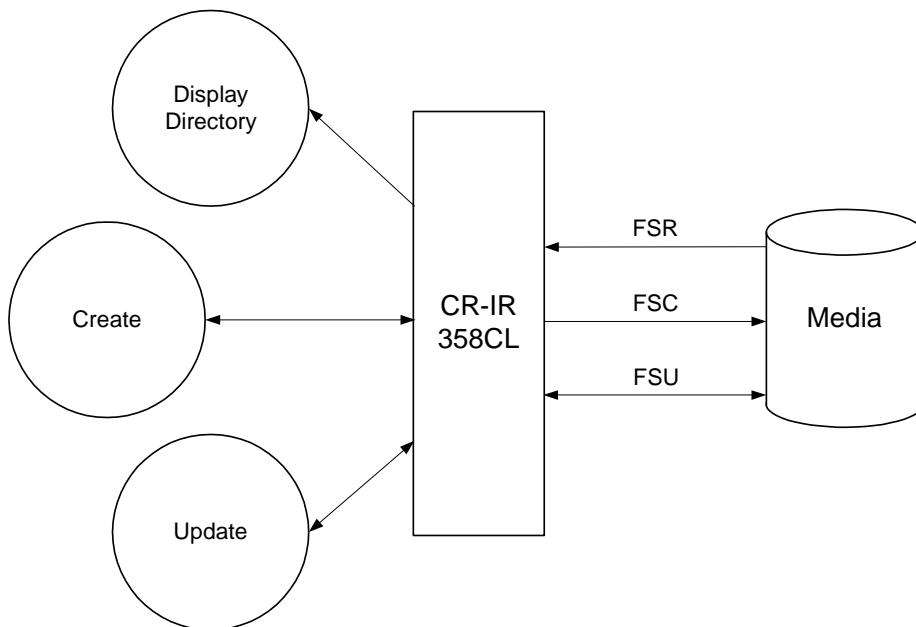

2.2 Functional Definitions of Application Entities

- The CR-IR 358CL writes agglomerated new DICOM files onto an initialized medium.
- The CR-IR 358CL updates the medium by adding new SOP instance to the existing agglomerated DICOM files.
- The CR-IR 358CL displays information of agglomerated DICOM files on the medium.

2.3 Sequencing of Real World Activities

Not applicable to Real World Activities.

2.4 File Meta Information for Implementation Class and Version

File Meta Information Version: 1

Implementation Class UID: "1.2.392.200036.9125.5342.1"

Implementation Version Name: "A00"

3. AE Specification

3.1 CR-IR 358CL AE Specification

The table below presents application profiles and roles supported by the CR-IR 358CL.

Application Profiles Supported	Real World Activity	Role	SC Option
STD-GEN-USB	Create	FSC	Interchange
	Display Directory	FSR	Interchange
	Update	FSU	Interchange

Note: All Application Profiles provide support to FSR and FSU in terms of agglomerated DICOM files created by the CR-IR 358CL.

3.1.1 File Meta Information for Application Entity

Source Application Entity Title will not be written. When determining private information, Private Information Creator UID and Private Information will be set up.

3.1.2 Real World Activities

3.1.2.1 Real World Activity: Create

In the case of a request for starting processing to an initialized medium, the CR-IR 358CL will run as FSC. The CR-IR 358CL generates DICOMDIR on the medium.

The following operations become possible on the CR-IR 358CL thereafter.

- Reading DICOMDIR information (Display Directory)
- Additionally registering and updating SOP instance (Update)

3.1.2.1.1 Application Profile: Create

See the table presented in “3.1 CR-IR 358CL AE Specification”.

3.1.2.2 Real World Activity: Display Directory

In the case of a request for starting processing to a medium on which the agglomerated DICOM files are written, the CR-IR 358CL will run as FSR.

The CR-IR 358CL reads DICOMDIR information stored on the medium and displays it in a list form in the unit of a study and image.

3.1.2.2.1 Application Profile: Display Directory

See the table presented in “3.1 CR-IR 358CL AE Specification”.

3.1.2.3 Real World Activity: Update

In the case of a request for additionally registering SOP instance to a medium on which the agglomerated DICOM files are written, the CR-IR 358CL will run as FSU.

Existing agglomerated DICOM files should exist on the medium on which the SOP instance is to be additionally registered.

The CR-IR 358CL writes on the medium an SOP instance that was requested so that it is additionally registered. The CR-IR 358CL will then edit DICOMDIR so that the SOP instance match appropriately with the agglomerated DICOM files thus changed. The CR-IR 358CL will then update the agglomerated DICOM files accordingly.

3.1.2.3.1 Application Profile: Update

See the table presented in “3.1 CR-IR 358CL AE Specification”.

3.2 SOP Classes and Transfer Syntaxes

SOP classes and transfer syntaxes are enumerated as shown in the table below.

Information Object Definition	SOP Class UID	Transfer Syntax	FSC Req.	FSR Req.	FSU Req.
Media Storage Directory	1.2.840.10008.1.3.10	Explicit VR Little Endian (1.2.840.10008.1.2.1)	M	M	M
CR Image Storage	1.2.840.10008.5.1.4.1.1.1	See next table.	O	M	O

Name	UID
Implicit VR Little Endian	1.2.840.10008.1.2
Explicit VR Little Endian	1.2.840.10008.1.2.1
JPEG Lossless Hierarchical First-Order Prediction	1.2.840.10008.1.2.4.70

4. Augmented Profiles

None.

5. Extensions, Specializations, Privatizations of SOP Classes and Transfer Syntaxes

None.

6. Configuration

The following system configuration is available for the CR-IR 358CL.

Disk Drive Installed	Profiles Supported
USB flash drive	STD-GEN-USB

7. Support of Extended Character Sets

- ISO-IR 100 (Latin Alphabet #1)
- ISO-IR 13/14 (Japanese Katakana: JIS X 0201)
- ISO-IR 87 (Japanese Kanji: JIS X 0208)
- ISO-IR 192 (Unicode: UTF-8)

8. Media Storage Directory IOD Overview

This section describes the Media Storage Directory IOD handled by the CR-IR 358CL.

8.1 Module Table

Module	Reference	Usage	DICOM Description	Implementation on CR-IR 358CL
File-set Identification	8.1.1	M	File-set identification information.	
Directory Information	8.1.2	U	<p>Directory Information followed by a Sequence of Directory Records.</p> <p>Note: The Directory Information Module is optional.</p> <p>This Directory Information Module should be present in all but primitive environments where a directory is not needed.</p> <p>In this case, only the File-set Identification Information is present.</p>	Handled as essential information.

8.1.1 File-set Identification Module

Attribute Name	Tag	Type	DICOM Definition	Implementation on CR-IR 358CL
File-set ID	(0004,1130)	2	<p>User or implementation specific Identifier (up to 16 characters).</p> <p>For definition, see DICOM PS 3.10.</p> <p>The File-set ID is intended to be a short human readable label to easily (but not necessarily uniquely) identify a specific File-set to facilitate operator manipulation of the physical media on which the File-set is stored. Assignment of Value and semantics are environment specific.</p>	A date is set in the form of YYYYMMHHMMSS.
File-set Descriptor File ID	(0004,1141)	3	ID of a File (in the same File-set) used for user comments related to the File-set (e.g. a readme file).	
Specific Character Set of File-set Descriptor File	(0004,1142)	1C	<p>Character set used in the File-set Descriptor File with a File ID as specified in File-set Descriptor File ID (0004,1141).</p> <p>Required to specify the expanded or replacement character set.</p> <p>If absent, only the Basic Graphic set is used.</p> <p>See DICOM PS 3.3 C.12.1.1.2 for Defined Terms.</p>	

8.1.2 Directory Information Module

Attribute Name	Tag	Type	DICOM Definition	Implementation on CR-IR 358CL
Offset of the First Directory Record of the Root Directory Entity	(0004,1200)	1	Offset of the first byte (of the Item Data Element) of the first Directory Record of the Root Directory Entity. This Offset is a number of bytes starting with the first byte of the File Meta Information. When the Root Directory Entity contains no Directory Record, this offset shall be set to 00000000H. Note: This offset includes the File Preamble and the DICM Prefix.	
Offset of the Last Directory Record of the Root Directory Entity	(0004,1202)	1	Offset of the first byte (of the Item Data Element) of the last Directory Record of the Root Directory Entity. This Offset is a number of bytes starting with the first byte of the File Meta Information. When the Root Directory Entity contains no Directory Record, this offset shall be set to 00000000H. Note: This offset includes the File Preamble and the DICM Prefix.	
File-set Consistency Flag	(0004,1212)	1	When set, this Flag indicates that an inconsistency within the Directory or between the Directory and the Files of the File-set may exist. Potential recovery actions are implementation specific and are beyond the scope of this Standard. Enumerated Values: 0000H: no known inconsistencies FFFFH: The FSR or FSU shall assume that inconsistencies are present.	
Directory Record Sequence	(0004,1220)	2	Sequence of zero or more repeating Items where each Item contains a Directory Record by including the Directory Elements from (0004,1400) to (0004,1511) and Record selection Keys as defined below (marked with a >). A zero length Value indicates that no Directory Records are contained in the Root Directory Entity.	
>Offset of the Next Directory Record	(0004,1400)	1C	Offset of the first byte (of the Item Data Element) of the next Directory Record of the same Directory Entity. This Offset is an unsigned integer representing a number of bytes starting with the first byte of the File Meta-information. A zero offset shall be used to mean that there is no other Directory Record in this Directory Entity. Required if the Directory Record Sequence (0004,1220) is not zero length. This Offset may be used to keep an inactive Record (0004,1410) chained with the next Directory Record of the same Directory Entity. Note: This offset includes the File Preamble and the DICM Prefix.	

>Record In-use Flag	(0004,1410)	1C	This flag facilitates the deletion of referenced files. Enumerated Values: FFFFH = Record is in use. 0000H = Record is inactive. All attributes of an inactive Directory Record except (0004,1400) and (0004,1410) shall be ignored.	
>Offset of Referenced Lower-Level Directory Entity	(0004,1420)	1C	Referenced Lower-Level Directory Entity Offset of the first byte (of the Item Data Element) of the first Directory Record of the Referenced Lower Level Directory Entity. This Offset is a number of bytes starting with the first byte of the File Meta Information. Required if the Directory Record Sequence (0004,1220) is not zero length. Note: This offset includes the File Preamble and the DICM Prefix.	
>Directory Record Type	(0004,1430)	1C	Defines a specialized type of Directory Record by reference to its position in the Media Storage Directory Information Model. Required if the Directory Record Sequence (0004,1220) is not zero length. Enumerated Values: PATIENT STUDY AGE OVERLAY MODALITY LUT VOI LUT CURVE TOPIC VISIT RESULTS INTERPRETATION STUDY COMPONENT STORED PRINT RT DOSE RT STRUCTURE SET RT PLAN RT TREAT RECORD PRESENTATION WAVEFORM SR DOCUMENT KEY OBJECT DOC PRIVATE MRDR	Sets the following enumerated values. PATIENT STUDY SERIES IMAGE
>Private Record UID	(0004,1432)	1C	Required if the Directory Record Type (0004,1430) is of Value PRIVATE.	

>Referenced File ID	(0004,1500)	1C	A Multiple Value (See DICOM PS 3.5) which represents the ordered components of the File ID containing a "referenced object" or Referenced SOP Instance. A maximum of 8 components, each from 1 to 8 characters shall be used. Note: The Referenced File ID provides the means to "locate" the File through the DICOM File Service provided by the Media Format Layer.	Determined when the Directory Record Type (0004,1430) is "IMAGE".
>MRDR Directory Record Offset	(0004,1504)	1C	Offset of the first byte (of the Item Data Element) of the Multi-Referenced File Directory Record.	
>Referenced SOP Class UID in File	(0004,1510)	1C	Unique ID for the SOP Class related to the IOD stored in the referenced File.	Determined when the Directory Record Type (0004,1430) is "IMAGE".
>Referenced SOP Instance UID in File	(0004,1511)	1C	Unique Identifier for the SOP Instance related to the IOD stored in the referenced file.	
>Referenced Transfer Syntax UID in File	(0004,1512)	1C	Transfer Syntax Unique Identifier for the Transfer Syntax used to encode the IOD stored in the referenced file.	
>Record Selection Keys	See 8.2.		A number of DICOM Data Elements which contain specific keys defined for each type of Directory Record (0004,1430).	See 8.2.

8.2 Relationship Between Directory Records

The table below shows directory record types included in the lower directory entities.

Directory Record Type	Reference	DICOM Definition	Implementation on CR-IR 358CL
(Root Directory Entity)	–	PATIENT, TOPIC, PRIVATE	PATIENT
PATINET		STUDY, PRIVATE	STUDY
STUDY		SERIES, VISIT, RESULTS, STUDY COMPONENT, PRIVATE	SEREIS
SERIES		IMAGE, OVERLAY MODARITY LUT, VOILUT CURVE, STORED PRINT, RT DOSE, RT STRUCTURE SET, RT PLAN, RT TREAT RECORD PRESENTATION, WAVEFORM, SR DOCUMENT, KEY OBJECT DOC, PRIVATE	IMAGE
IMAGE		PRIVATE	

8.2.1 Patient Directory Record Definition

Key	Tag	Type	Attribute Description
Specific Character Set	(0008,0005)	1C	To be set up when agglomerated extension or substitute characters are used.
Patient's Name	(0010,0010)	2	
Patient ID	(0010,0020)	1	
Patient's Birthday	(0010,0030)	3	
Patient's Sex	(0010,0040)	3	

8.2.2 Study Directory Record Definition

Key	Tag	Type	Attribute Description
Specific Character Set	(0008,0005)	1C	To be set up when agglomerated extension or substitute characters are used.
Study Date	(0008,0020)	1	
Study Time	(0008,0030)	1	
Study Description	(0008,1030)	2	
Study Instance UID	(0020,000D)	1	
Study ID	(0020,0010)	1	
Accession Number	(0008,0050)	2	
Referring Physician's Name	(0008,0090)	3	
Requesting Service	(0032,1033)	3	

8.2.3 Series Directory Record Definition

Key	Tag	Type	Attribute Description
Specific Character Set	(0008,0005)	1C	To be set up when agglomerated extension or substitute characters are used.
Modality	(0008,0060)	1	
Series Instance UID	(0020,000E)	1	
Series Number	(0020,0011)	1	
Body Part Examined	(0018,0015)	3	

8.2.4 Image Directory Record Definition

Key	Tag	Type	Attribute Description
Specific Character Set	(0008,0005)	1C	To be set up when agglomerated extension or substitute characters are used.
Image Number	(0020,0013)	1	
Image Type	(0008,0008)	1C	To be set up essentially for CD-R storage. Setup needed also for other than CD-R storage.
SOP Instance UID	(0008,0018)	3	
Content Date	(0008,0023)	3	
Content Time	(0008,0033)	3	
Acquisition Device Processing Description	(0018,1400)	3	
Acquisition Device Processing Code	(0018,1401)	3	
FCR Image ID	(0021,xx10)	3	This key is private attribute. ID of an image generated by the Fuji system, consisting of the four characters. For a CR image, the first one character constitutes an ID that identifies each device, and the remaining three characters constitute a serial number for an image generated by a certain device. Numbers from 000 to 999 are used cyclically.

FUJIFILM

FUJIFILM Corporation

26-30, NISHIAZABU 2-CHOME, MINATO-KU, TOKYO 106-8620, JAPAN