



DICOM Conformance Statement

FDR-1000AWS

FDR-2000AWS

FDR-3000AWS

CR-IR363AWS

for

DICOM Storage

DICOM Storage Commitment

DICOM MWM

DICOM MPPS

DICOM Print

DICOM Query / Retrieve

DICOM Media Storage

DICOM Dose SR

(Standard)

April, 2016

19th Edition

Copyright FUJIFILM Corporation, Japan

CONTENTS

1...CONFORMANCE STATEMENT OVERVIEW 4

2...LIST OF TABLES AND FIGURES5

3...INTRODUCTION..... 11

 3.1..... REVISION HISTORY 11

 3.2..... AUDIENCE..... 11

 3.3..... REMARKS..... 11

 3.4..... DEFINITIONS, TERMS AND ABBREVIATIONS 12

 3.5..... REFERENCES 12

4...NETWORKING..... 13

 4.1 IMPLEMENTATION MODEL 13

 4.1.2.... Functional Definition of AEs 14

 4.1.3.... Sequencing of Real-World Activities 16

 4.2..... AE SPECIFICATIONS 17

 4.2.1.... Verification-SCU Application Entity Specification..... 17

 4.2.2.... Storage-SCU Application Entity Specification 19

 4.2.3.... Storage Commitment-SCU Application Entity Specification..... 22

 4.2.4.... MWM-SCU Application Entity Specification 26

 4.2.5.... MPPS-SCU Application Entity Specification..... 31

 4.2.6.... Print-SCU Application Entity Specification 37

 4.2.7.... Q/R-SCU Application Entity Specification 44

 4.2.8.... Storage-SCP Application Entity Specification 48

 4.3..... NETWORK INTERFACES 52

 4.3.1.... Physical Network Interface 52

 4.3.2.... Additional Protocols 52

 4.3.3.... IPv4 and IPv6 Support..... 52

 4.4..... CONFIGURATION 52

 4.4.1.... AE Title/Presentation Address Mapping..... 52

 4.4.2.... Parameters 53

5...MEDIA INTERCHANGE..... 55

 5.1..... IMPLEMENTATION MODEL 55

 5.1.1.... Application Data Flow 55

 5.1.2.... Functional Definition of AEs 55

 5.1.3.... Sequencing of Real-World Activities 56

 5.1.4.... File Meta Information Options 56

 5.2..... AE SPECIFICATIONS 56

 5.2.1.... Offline-Media Application Entity Specification 56

 5.3..... AUGMENTED AND PRIVATE APPLICATION PROFILES 58

 5.3.1.... Augmented Application Profiles..... 58

 5.3.2.... Private Application Profiles 59

 5.4..... MEDIA CONFIGURATION..... 59

6...SUPPORT OF CHARACTER SETS 60

7...SECURTIY 61

8...ANNEXES 62

 8.1..... IOD CONTENTS 62

 8.1.1.... Created SOP Instances 62

 8.1.2.... Used Fields in received IOD by application..... 153

 8.1.3.... Attribute mapping..... 153

 8.1.4.... Coerced/Modified Fields 154

 8.1.5.... STRUCTURED REPORT DOCUMENT INFORMATIONS 154

8.2.....	MEDIA STORAGE DIRECTORY IOD OBERVIEW	160
8.2.1....	Module Table	160
8.2.1.1.	File-set Identification Module.....	160
8.2.1.2.	Directory Information Module	161
8.2.2....	Relationship Between Directory Records	164
8.2.2.1.	Patient Directory Record Definition	164
8.2.2.2.	Study Directory Record Definition	164
8.2.2.3.	Series Directory Record Definition	165
8.2.2.4.	Image Directory Record Definition	165
8.3.....	DATA DICTIONARY OF PRIVATE ATTRIBUTES	166
8.4.....	CODED TERMINOLOGY AND TEMPLATES	170
8.5.....	GRAYSCALE IMAGE CONSISTENCY	170
8.6.....	STANDARD EXTENDED / SPECIALIZED / PRIVATE SOP CLASSES	170
8.6.1....	Standard Extended SOP Class - Computed Radiography Image Storage.....	170
8.6.2....	Standard Extended SOP Class - Digital Mammography X-Ray Image Storage.....	170
8.6.3....	Standard Extended SOP Class – Breast Tomosynthesis Image Storage	170
8.7.....	PRIVATE TRANSFER SYNTAXES	170

1 CONFORMANCE STATEMENT OVERVIEW

Table 1-1 provides an overview of the network services supported by AWS.

The AWS implements the necessary DICOM services to save acquired images to a network storage device.

TABLE 1- 1 NETWORK SERVICES

SOP Classes	User of Service (SCU)	Provider of Service (SCP)
Transfer		
Computed Radiography Image Storage	Yes	Yes
Digital Mammography X-Ray Image Storage – For Presentation	Yes	Yes
Digital Mammography X-Ray Image Storage – For Processing	Yes	Yes
Breast Tomosynthesis Image Storage	Yes	No
Key Object Selection Document	Yes	No
X-Ray Radiation Dose SR	Yes	No
Workflow Management		
Modality Worklist Information Model – FIND	Yes	No
Modality Performed Procedure Step	Yes	No
Storage Commitment Push Model	Yes	No
Query/Retrieve		
Study Root Query/Retrieve Information Model - FIND	Yes	No
Study Root Query/Retrieve Information Model - MOVE	Yes	No
Print Management		
Basic Grayscale Print Management Meta	Yes	No

Table 1-2 provides an overview of the Media Storage Application Profiles supported by AWS.

TABLE 1- 2 MEDIA SERVICES

Media Storage Application Profile	Write Files (FSC)	Read Files (FSR)
DVD		
General Purpose DVD ± RW	Yes	Yes
USB drive		
General Purpose USB drive	Yes	Yes

2 LIST OF TABLES AND FIGURES

Table 1- 1 Network Services	4
Table 1- 2 Media Services	4
Table 4.2- 3 SOP Classes for The Verification-SCU AE	17
Table 4.2- 4 DICOM Application Context for The Verification-SCU AE	17
Table 4.2- 5 Number of Associations Initiated for The Verification -SCU AE	17
Table 4.2- 6 Asynchronous Nature for The Verification-SCU AE	17
Table 4.2- 7 DICOM Implementation Class and Version for The Verification-SCU AE	17
Table 4.2- 8 Proposed Presentation Contexts for Activity Verify Connection	18
Table 4.2- 9 Verification Response Status Handling Behavior	18
Table 4.2- 10 SOP Classes for The Storage-SCU AE	19
Table 4.2- 11 DICOM Application Context for The Storage-SCU AE	19
Table 4.2- 12 Number of Associations Initiated for The Storage-SCU AE	20
Table 4.2- 13 Asynchronous Nature for The Storage-SCU AE	20
Table 4.2- 14 DICOM Implementation Class and Version for The Storage-SCU AE	20
Table 4.2- 15 Proposed Presentation Contexts for Activity Send Images	21
Table 4.2- 16 Storage C-STORE Response Status Handling Behavior	22
Table 4.2- 17 SOP Classes for The Storage Commitment-SCU AE	22
Table 4.2- 18 DICOM Application Context for The Storage Commitment-SCU AE	22
Table 4.2- 19 Number of Associations Initiated for The Storage Commitment-SCU AE	22
Table 4.2- 20 Number of Associations Accepted for The Storage Commitment-SCU AE	22
Table 4.2- 21 Asynchronous Nature for The Storage Commitment-SCU AE	22
Table 4.2- 22 DICOM Implementation Class and Version for The Storage Commitment-SCU AE	23
Table 4.2- 23 Proposed Presentation Contexts for Activity Commit Send Images	24
Table 4.2- 24 Storage Commitment N-ACTION Response Status Handling Behavior	24
Table 4.2- 25 Proposed Presentation Contexts for Activity Receive Storage Commitment	25
Table 4.2- 26 Storage Commitment N-EVENT-REPORT Behavior	25
Table 4.2- 27 Storage Commitment N-EVENT-REPORT Responce Status Reasons	25
Table 4.2- 28 SOP Classes for The MWM-SCU AE	26
Table 4.2- 29 DICOM Application Context for The MWM-SCU AE	26
Table 4.2- 30 Number of Associations Initiated for The MWM-SCU AE	26

Table 4.2- 31 Asynchronous Nature for The MWM-SCU AE	26
Table 4.2- 32 DICOM Implementation Class and Version for The MWM-SCU AE	27
Table 4.2- 33 Proposed Presentation Contexts for Activity Update Worklist	29
Table 4.2- 34 Modality Worklist C-FIND Response Status Handling Behavior	29
Table 4.2- 35 Worklist Request Identifier	29
Table 4.2- 36 SOP Classes for The MPPS-SCU AE	32
Table 4.2- 37 DICOM Application Context for The MPPS-SCU AE	32
Table 4.2- 38 Number of Associations Initiated for The MPPS-SCU AE	32
Table 4.2- 39 Asynchronous Nature for The MPPS-SCU AE	32
Table 4.2- 40 DICOM Implementation Class and Version for The MPPS-SCU AE	32
Table 4.2- 41 Proposed Presentation Contexts for Acquire Images	33
Table 4.2- 42 MPPS N-CREATE / N-SET Response Handling Behavior	34
Table 4.2- 43 MPPS N-CREATE / N-SET Request Identifier	34
Table 4.2- 44 META SOP Classes for The Print-SCU AE	37
Table 4.2- 45 SOP Classes for The Print-SCU AE	37
Table 4.2- 46 DICOM Application Context for The Print-SCU AE	37
Table 4.2- 47 Number of Associations Initiated for The Print-SCU AE	37
Table 4.2- 48 Asynchronous Nature for The Print-SCU AE	37
Table 4.2- 49 DICOM Implementation Class and Version for The Print-SCU AE	38
Table 4.2- 50 Proposed Presentation Contexts for Activity Film Images	39
Table 4.2- 51 PRINTER SOP CLASS N-GET Request Attributes	39
Table 4.2- 52 PRINTER SOP CLASS N-GET Response Status Handling Behavior	39
Table 4.2- 53 PRINTER SOP CLASS N-EVENT-REPORT Behavior	40
Table 4.2- 54 PRINTER SOP CLASS N-EVENT-REPORT Response Status Reasons	40
Table 4.2- 55 FILM SESSION SOP CLASS N-CREATE Request Attributes	40
Table 4.2- 56 FILM SESSION SOP CLASS N-CREATE Response Handling Behavior	41
Table 4.2- 57 FILM SESSION SOP CLASS N-DELETE Response Handling Behavior	41
Table 4.2- 58 FILM BOX SOP CLASS N-CREATE Request Attributes	41
Table 4.2- 59 FILM BOX SOP CLASS N-CREATE Response Handling Behavior	42
Table 4.2- 60 FILM BOX SOP CLASS N-ACTION Response Handling Behavior	42
Table 4.2- 61 Basic Grayscale Image Box SOP CLASS N-SET Request Attributes	43
Table 4.2- 62 Basic Grayscale Image Box SOP CLASS N-SET Response Handling Behavior	44
Table 4.2- 63 SOP Classes for The Q/R-SCU AE	44

Table 4.2- 64	DICOM Application Context for The Q/R-SCU AE	44
Table 4.2- 65	Number of Associations Initiated for The Q/R-SCU AE	44
Table 4.2- 66	Asynchronous Nature for The Q/R-SCU AE	45
Table 4.2- 67	DICOM Implementation Class and Version for The Q/R-SCU AE	45
Table 4.2- 68	Proposed Presentation Contexts for Activity Query and Retrieve Image	46
Table 4.2- 69	Q/R C-FIND Response Status Handling Behavior	46
Table 4.2- 70	STUDY ROOT Request Identifier FOR C-FIND	47
Table 4.2- 71	Q/R C-MOVE Response Status Handling Behavior	48
Table 4.2- 72	SOP Classes for The Storage-SCP AE	48
Table 4.2- 73	DICOM Application Context for The Storage-SCP AE	49
Table 4.2- 74	Number of Associations Initiated for The Storage-SCP AE	49
Table 4.2- 75	Asynchronous Nature for The Storage-SCP AE	49
Table 4.2- 76	DICOM Implementation Class and Version for The Storage-SCP AE	49
Table 4.2- 77	Proposed Presentation Contexts for Activity Store Images	50
Table 4.2- 78	The Storage-SCP AE C-STORE Response Status Return Reasons	51
Table 4.3- 1	Supported Physical Network Interfaces	52
Table 4.4- 1	AE Title Configuration Table	52
Table 4.4- 2	CONFIGURATION PARAMETERS TABLE	53
Table 5.1-1	DICOM Implementation Class and Version for Media Storage	56
Table 5.2-1	Application Profiles, Activities and Roles for Offline-Media	57
Table 5.3-1	Augmented Application Profiles	58
Table 5.3-2	SOP Class Augmentations	58
Table 5.4-1	AE Title Configuration Table	59
Table 8.1- 1	IOD of created CR Image storage SOP Instances	63
Table 8.1- 2	IOD of created MG Image Storage SOP Instances	64
Table 8.1- 3-1	IOD of BREAST TOMOSYNTHESIS IMAGE STORAGE SOP Instances	66
Table 8.1- 3-2	IOD of BREAST TOMOSYNTHESIS IMAGE STORAGE SOP Instances	67
Table 8.1- 4	IOD of Key Object Selection Document SOP Instances	69
Table 8.1- 5	IOD of created X-RAY RADIATION DOSE SR SOP Instances	70
Table 8.1- 6	Patient Module of created SOP Instances	71
Table 8.1- 7	General Study Module of created SOP Instances	72
Table 8.1- 8	Patient Study Module of created SOP Instances	73
Table 8.1- 9	General Series Module of created SOP Instances	74

Table 8.1- 10 CR Series Module of created CR IMage storage SOP Instances	77
Table 8.1- 11 DX Series Module of created MG IMage storage SOP Instances	78
Table 8.1- 12 Mammography Series Module of created MG IMage storage SOP Instances	79
Table 8.1- 13 ENHANCED MammograpHy Series Module of created BREAST TOMOSYNTHESIS IMage storage SOP Instances	80
Table 8.1- 14 FRAME OF REFERENCE Module of created BREAST TOMOSYNTHESIS IMage storage SOP Instances	81
Table 8.1- 15 General Equipment Module of created SOP Instances	82
Table 8.1- 16 ENHANCED General Equipment Module of created SOP Instances	83
Table 8.1- 17 General Image Module of created SOP Instances	84
Table 8.1- 18 Image PLANE Module of created SOP Instances	89
Table 8.1- 19 Image Pixel Module of created SOP Instances	90
Table 8.1- 20 Contrast/Bolus Module of created SOP Instances	92
Table 8.1- 21 CR image Module of created CR Image Storage SOP Instances	93
Table 8.1- 22 DX image Module of created MG Image Storage SOP Instances	96
Table 8.1- 23 Mammography Image Module of created MG Image Storage SOP Instances	101
Table 8.1- 24 DX Detector Module of created MG Image Storage SOP Instances	104
Table 8.1- 25 DX Positioning Module of created SOP Instances	106
Table 8.1- 26 X-ray TOMOGRAPHY Acquisition Module of created MG Image Storage SOP Instances	107
Table 8.1- 27 X-RAY Acquisition Dose Module of created SOP Instances	108
Table 8.1- 28 X-RAY GENERATION Module of created SOP Instances	112
Table 8.1- 29 X-RAY Grid Module of created SOP Instances	113
Table 8.1- 30 Modality LUT Module of created CR IMAGE STORAGE SOP Instances	114
Table 8.1- 31 VOI LUT Module of created SOP Instances	116
Table 8.1- 32 Acquisition Context Module of created MG IMAGE STORAGE SOP Instances	118
Table 8.1- 33 MULTI-FRAME FUNCTIONAL GROUPS MODULE of created breast Tomosynthesis IMAGE STORAGE SOP Instances	119
Table 8.1- 34 Functional Group macros ATTRIBUTES	122
Table 8.1- 35 X-RAY 3D Image module of created BREAST Tomosynthesis IMAGE STORAGE SOP Instances	129
Table 8.1- 36 Breast Tomosynthesis Contributing Sources of created Breast tomosynthesis Image STORAGE SOP Instances	132
Table 8.1- 37 breast tomosynthesis acquisition of created breast tomosynthesis IMAGE STORAGE SOP Instances	135
Table 8.1- 38 X-ray 3D ReconstRuction of created breast tomosynthesis IMAGE STORAGE SOP Instances	140

Table 8.1- 39 BREAST VIEW MODULE of created breast Tomosynthesis IMAGE STORAGE SOP Instances	141
Table 8.1- 40 SOP Common Module of created SOP Instances	143
Table 8.1- 41 KEY object Document Module of created SOP Instances	144
Table 8.1- 42 KEY object Document Series Module of created SOP Instances	145
Table 8.1- 43 SR Document Content Module of created SOP Instances	146
Table 8.1- 44 DOCUMENT CONTENT MACRO ATTRIBUTES	146
Table 8.1- 45 DOCUMENT RELATIONSHIP MACRO ATTRIBUTES	148
Table 8.1- 46 NUMERIC MESUREMENT MACRO ATTRIBUTES	149
Table 8.1- 47 CODE MACRO ATTRIBUTES	150
Table 8.1- 48 IMAGE REFERENCE MACRO ATTRIBUTES	150
Table 8.1- 49 CONTAINER MACRO ATTRIBUTES	150
Table 8.1- 50 SR DOCUMENT SERIES MODULE OF CREATED X-RAY RADIATION DOSE SR SOP INSTANCES	152
Table 8.1- 51 SR DOCUMENT GENERAL MODULE OF CREATED X-RAY RADIATION DOSE SR SOP INSTANCES	152
Table 8.1- 52 ATTRIBUTE MAPPING BETWEEN MODALITY WORKLIST, IMAGE AND MPPS	153
Table 8.1- 53 KEY OBJECT SELECTION Structure	154
Table 8.1- 54 Projection X-Ray Radiation Dose Structure	156
Table 8.1- 55 OBSERVER CONTEXT STRUCTURE	156
Table 8.1- 56 ACCUMULATED X-RAY DOSE DATA STRUCTURE	157
Table 8.1- 57 ACCUMULATED MAMMOGRAPHY X-RAY DOSE DATA STRUCTURE	157
TABLE 8.1- 58 Irradiation Event X-Ray Data	157
Table 8.1- 59 DEVICE PARTICIPANT	159
Table 8.2- 1 BASIC DIRECTORY IOD MODULES	160
Table 8.2- 2 FILE-SET IDENTIFICATION MODULE	160
Table 8.2- 3 DIRECTORY INFORMATION MODULE	161
Table 8.2- 4 Relationship Between Directory Records	164
Table 8.2- 5 PATIENT KEYS	164
Table 8.2- 6 STUDY KEYS	164
Table 8.2- 7 SERIES KEYS	165
Table 8.2- 8 IMAGE KEYS	165
Table 8.3- 1 Data Dictionary of Private Attributes	166

Figure 4.1- 1 Application Data Flow Diagram	13
Figure 4.1- 2 Sequencing Constraints	16
Figure 4.2- 3 Sequencing of Activity – Verify Connection	18
Figure 4.2- 4 Sequencing of Activity – Send Images & Documents	20
Figure 4.2- 5 Sequencing of Activity – Commit Sent Images	23
Figure 4.2- 6 Sequencing of Activity – Receive Storage Commitment	24
Figure 4.2- 7 Sequencing of Activity – Update Worklist	28
Figure 4.2- 8 Sequencing of Activity – Acquire Images	33
Figure 4.2- 9 Sequencing of Activity – Film Images	38
Figure 4.2- 10 Sequencing of Activity – Query and Retrieve Image	45
Figure 4.2- 11 Sequencing of Activity – Store Images to The Local File System	50
Figure 5.1- 1 Application Data Flow Diagram for Media Storage	55

3 INTRODUCTION

3.1 REVISION HISTORY

Document Version	Date of Issue	Author	Description
1.0	June, 2008	FUJIFILM	Version for Final Text
2.0	December, 2008	FUJIFILM	Change format based on DICOM 2007
3.0	March, 2010	FUJIFILM	Update to AWS V3.0
3.1	August, 2010	FUJIFILM	Update to AWS V3.1
3.2	January, 2011	FUJIFILM	Update to AWS V3.1(FDR-2000AWS is added.)
4.0	May, 2011	FUJIFILM	Update to AWS V4.0
4.1	November, 2011	FUJIFILM	Update to AWS V4.1
4.2	June, 2012	FUJIFILM	Update to AWS V4.2
5.0	February, 2013	FUJIFILM	Update to AWS V5.0(FDR-3000AWS is added.)
5.1	August, 2013	FUJIFILM	Update to AWS V5.1
5.2	March, 2014	FUJIFILM	Update to AWS V5.2
6.0	March, 2015	FUJIFILM	Update to AWS V6.0
6.1	October, 2015	FUJIFILM	Update to AWS V6.1
7.0	April, 2016	FUJIFILM	Update to AWS V7.0

3.2 AUDIENCE

This document is intended for hospital staff, health system integrators, software designers or implementers. It is assumed that the reader has a working understanding of DICOM.

3.3 REMARKS

DICOM, by itself, does not guarantee interoperability. However, the Conformance Statement facilitates a first-level validation for interoperability between different applications supporting the same DICOM functionality.

This Conformance Statement is not intended to replace validation with other DICOM equipment to ensure proper exchange of information intended.

The scope of this Conformance Statement is to facilitate communication with FUJIFILM and other vendors' Medical equipment. The Conformance Statement should be read and understood in conjunction with the DICOM Standard [DICOM]. However, by itself it is not guaranteed to ensure the desired interoperability and a successful interconnectivity.

The user should be aware of the following important issues:

- The comparison of different conformance statements is the first step towards assessing interconnectivity between FUJIFILM and non- FUJIFILM equipment.
- Test procedures should be defined to validate the desired level of connectivity.

- The DICOM standard will evolve to meet the users' future requirements. FUJIFILM is actively involved in developing the standard further and therefore reserves the right to make changes to its products or to discontinue its delivery.

3.4 DEFINITIONS, TERMS AND ABBREVIATIONS

Definitions, terms and abbreviations used in this document are defined within the different parts of the DICOM standard.

Abbreviations and terms are as follows:

AE	DICOM Application Entity
CR	Computed Radiography
FSC	File-Set Creator
FSU	File-Set Updater
FSR	File-Set Reader
IE	Information Entity
IOD	(DICOM) Information Object Definition
ISO	International Standard Organization
KOS	Key Object Selection Document
MG	Mammography
PDU	DICOM Protocol Data Unit
SCU	DICOM Service Class User (DICOM client)
SCP	DICOM Service Class Provider (DICOM server)
SOP	DICOM Service-Object Pair
TCP/IP	Transmission Control Protocol/Internet Protocol
UID	Unique Identifier
VM	Value Multiplicity
VR	Value Representation

3.5 REFERENCES

[DICOM]Digital Imaging and Communications in Medicine (DICOM), NEMA PS 3.1-3.18, 2007

4 NETWORKING

4.1 IMPLEMENTATION MODEL

4.1.1 Application Data

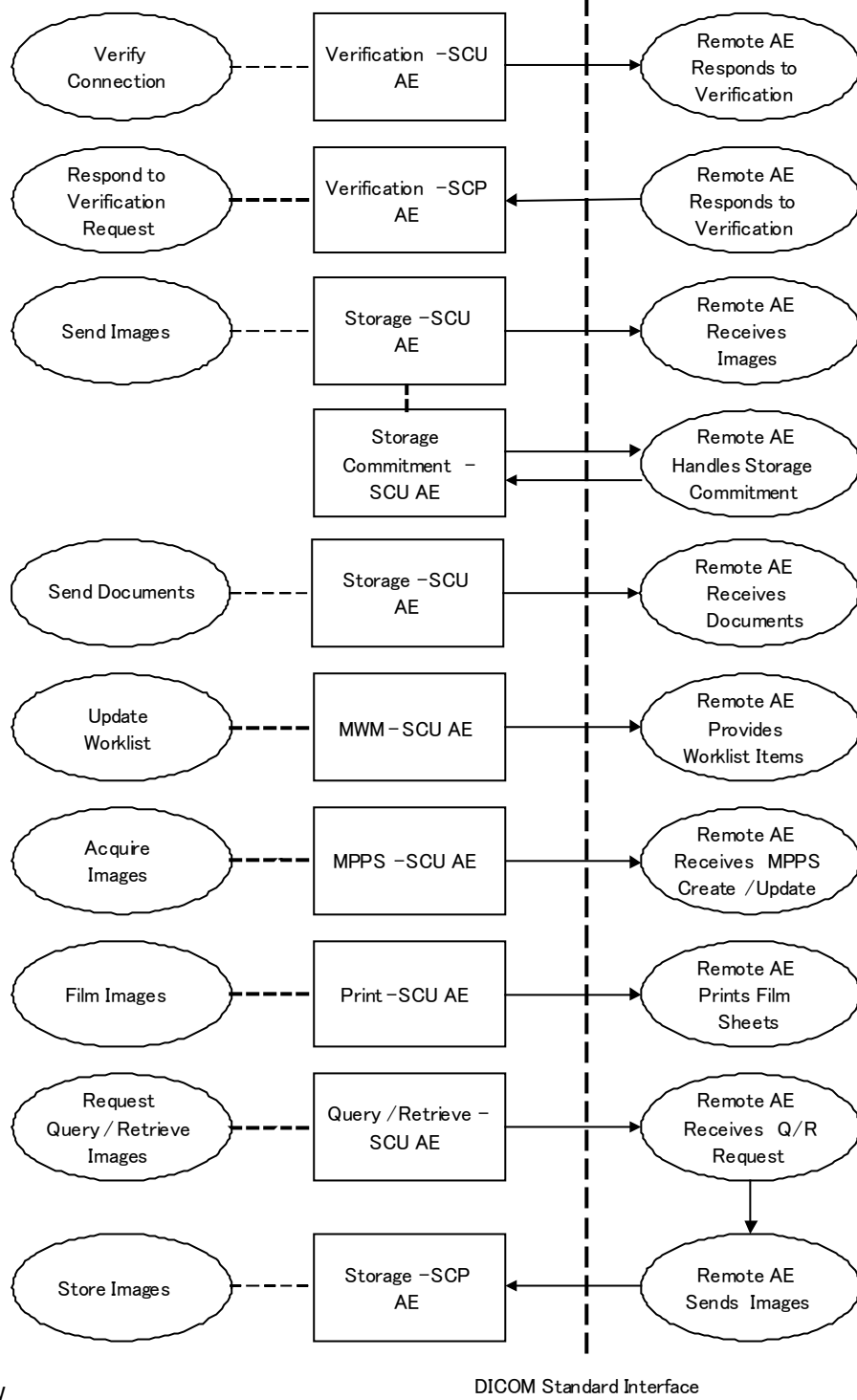

FIGURE 4.1- 1 APPLICATION DATA FLOW DIAGRAM

— The Verification-SCU AE issues a C-ECHO to verify a DICOM connection to a remote AE. It is associated with the local real-world activity “Verify Connectivity”. “Verify Connectivity” is performed via the Service Tool.

- The Verification SCP AE responds successfully to C-ECHO requests from known AE Titles. It is associated with the local real-world activity “Respond to Verification Request”.
- The Storage-SCU Application Entity sends images or documents to a remote AE. It is associated with the local real-world activity “Send Images” and “Send Documents”. “Send Images” and “Send Documents” are performed upon user request for each study completed or for specific images and documents selected. When activated by user’s settings (auto-send), each marked set of images and documents can be immediately stored to a preferred destination whenever a Patient/Study is closed by the user.
- Receiving the storage commitment request from the Storage-SCU AE, the Storage Commitment-SCU AE will request Storage Commitment and record commitment information in the local database if a commitment is successfully obtained.
- The MWM-SCU Application Entity receives Worklist information from a remote AE. It is associated with the local real-world activities “Update Worklist”. When the “Update Worklist” local real-world activity is performed the MWM-SCU Application Entity queries a remote AE for worklist items and provides the set of worklist items matching the query request. “Update Worklist” is performed as a result of an operator request or can be performed automatically at specific time intervals.
- The MPPS-SCU Application Entity sends MPPS information to a remote AE. When the “Acquire Images” local real-world activity is performed the MPPS-SCU Application Entity creates and updates Modality Performed Procedure Step instances managed by a remote AE. Acquisition of images will result in automated creation of an MPPS Instance. Completion of the MPPS is performed as the result of an operator action.
- The Print-SCU Application Entity prints images on a remote AE (Printer). It is associated with the local real-world activity “Film Images”. “Film Images” creates a print-job within the print queue containing one or more virtual film sheets composed from images selected by the user.
- The Query/Retrieve-SCU Application Entity queries remote AEs for lists of studies, series and instances and retrieves selected studies, series or instances from lists. It is associated with the local real-world activity “Requests Query/Retrieve”.
- The Storage-SCP Application Entity receives incoming images. It is associated with the local real-world activity “Store Images”.

4.1.2 Functional Definition of AEs

4.1.2.1 Functional Definition of Verification-SCU Application Entity

The Verification-SCU AE issues a C-ECHO to verify a DICOM connection to a remote AE. It is performed via the Service Tool.

4.1.2.2 Functional Definition of Verification-SCP Application Entity

The Verification-SCP AE responds successfully to C-ECHO requests from known AE Titles.

4.1.2.3 Functional Definition of Storage-SCU Application Entity

The existence of a send-job queue entry with associated network destination will activate the Storage-SCU AE. An association request is sent to the destination AE and upon successful negotiation of a Presentation Context the image transfer is started. If the association cannot be opened, the related send-job is set to an error state. By default, the Storage AE will retry to initiate another association for this send-job automatically.

4.1.2.4 Functional Definition of Storage Commitment-SCU Application Entity

The Storage Commitment-SCU AE receiving the storage commitment request from the Storage-SCU AE, the Storage Commitment-SCU AE will request Storage Commitment and record commitment information in the local database if a commitment is successfully obtained.

4.1.2.5 Functional Definition of MWM-SCU Application Entity

Worklist Update attempts to download a Worklist from a remote node. If the MWM-SCU AE establishes an Association to a remote AE, it will transfer all worklist items via the open Association. During receiving the worklist response items are counted and the query processing is canceled if the configurable limit of items is reached. The results will be displayed in a separate list, which will be cleared with the next Worklist Update.

4.1.2.6 Functional Definition of MPPS-SCU Application Entity

The MPPS-SCU AE creates an MPPS Instance automatically when the user selects and starts a worklist item. And the MPPS data is updated when the user completes the acquisition.

4.1.2.7 Functional Definition of Print-SCU Application Entity

The existence of a print-job in the print queue will activate the Print-SCU AE. An association is established with the printer and the printer's status determined. If the printer is operating normally, the film sheets described within the print-job will be printed. Changes in printer status will be detected (e.g. out of film) and reported to the user. If the printer is not operating normally, the print-job will set to an error state and can be restarted by the user via the job control interface.

4.1.2.8 Functional Definition of Query/Retrieve-SCU Application Entity

The Query/Retrieve-SCU Application Entity is activated through the user interface when a user selects a remote AE to query (from a pre-configured list), then initiates a query. Queries are performed recursively from the study through the series and instance levels until all matching instances have been listed. And the Query/Retrieve AE is activated through the user interface when a user selects a study, series or instance for retrieval. A connection to the remote AE is established to initiate and monitor the retrieval and the Storage-SCP AE receives the retrieved instances.

4.1.2.9 Functional Definition of Storage-SCP Application Entity

Storage-SCP waits in the background for connections, will accept associations with Presentation Contexts for SOP Classes of the Storage Service Class, and will store the received instances to the local database where they may subsequently be listed and viewed through the user interface.

4.1.3 Sequencing of Real-World Activities

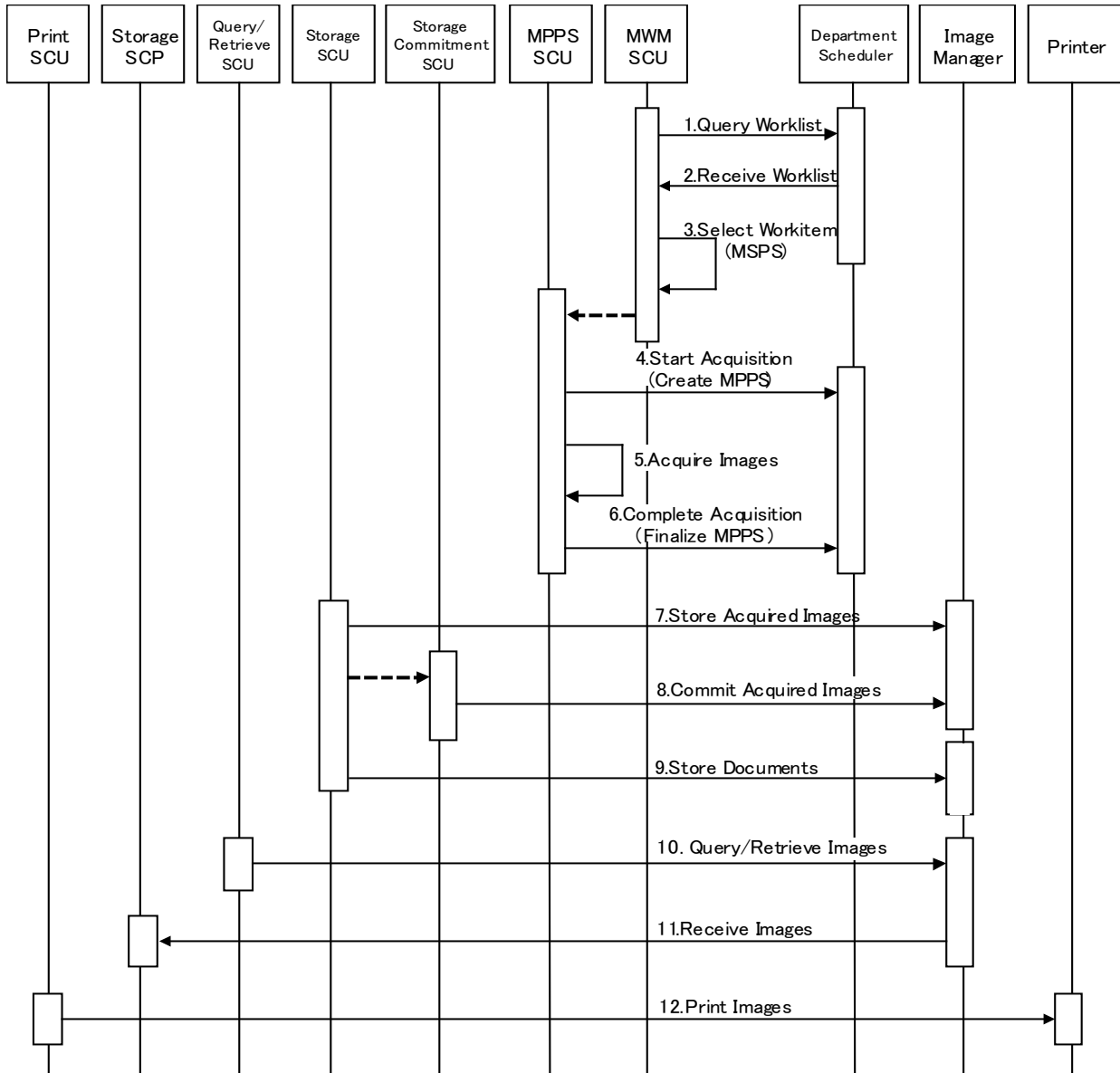

FIGURE 4.1- 2 SEQUENCING CONSTRAINTS

Under normal workflow conditions the sequencing constraints illustrated in Figure 4.1-2 apply:

1. Query Worklist
2. Receive Worklist
3. Select Workitem (MSPS)
4. Start Acquisition (Create MPPS)
5. Acquire Images
6. Complete Acquisition (Finalize MPPS)
7. Store Acquired Images
8. Commit Acquired Images
9. Store Documents
10. Query/Retrieve Images
11. Receive Images

12. Print Images

Other workflow situations (e.g. auto-send) will have other sequencing constraints.

4.2 AE SPECIFICATIONS

4.2.1 Verification-SCU Application Entity Specification

4.2.1.1 SOP Classes

AWS provides Standard Conformance to the following SOP Classes:

TABLE 4.2- 3 SOP CLASSES FOR THE VERIFICATION-SCU AE

SOP Class Name	SOP Class UID	SCU	SCP
Verification	1.2.840.10008.1.1	Yes	No

4.2.1.2 Association Policies

4.2.1.2.1 General

The DICOM standard application context name for DICOM 3.0 is always proposed:

TABLE 4.2- 4 DICOM APPLICATION CONTEXT FOR THE VERIFICATION-SCU AE

Application Context Name	1.2.840.10008.3.1.1.1
--------------------------	-----------------------

4.2.1.2.2 Number of Associations

AWS initiates one Association at a time for each destination to which a transfer request is being processed in the active job queue list. Only one job will be active at a time, the other remains pending until the active job is completed or failed.

TABLE 4.2- 5 NUMBER OF ASSOCIATIONS INITIATED FOR THE VERIFICATION -SCU AE

Maximum number of simultaneous Associations	1
---	---

4.2.1.2.3 Asynchronous Nature

AWS does not support asynchronous communication (multiple outstanding transactions over a single Association).

TABLE 4.2- 6 ASYNCHRONOUS NATURE FOR THE VERIFICATION-SCU AE

Maximum number of outstanding asynchronous transactions	1
---	---

4.2.1.2.4 Implementation Identifying Information

The implementation information for this Application Entity is:

TABLE 4.2- 7 DICOM IMPLEMENTATION CLASS AND VERSION FOR THE VERIFICATION-SCU AE

Implementation Class UID	1.2.392.200036.9125.5342.1
Implementation Version Name	A00

4.2.1.3 Association Initiation Policy

4.2.1.3.1 Activity – Send Images

4.2.1.3.1.1 Description and Sequencing of Activities

The AWS will acquire images and send those images automatically to the pre-set remote host or select images from the list of images thus stored and send them to the specified destination.

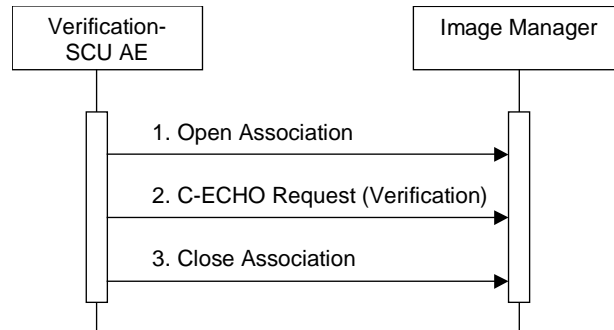

FIGURE 4.2- 3 SEQUENCING OF ACTIVITY – VERIFY CONNECTION

A possible sequence of interactions between the Storage-SCU AE and an Image Manager (e.g. a storage or archive device supporting the Storage SOP Classes as an SCP) is illustrated in Figure above:

1. The Verification-SCU AE opens an association with the Image Manager
2. The Verification-SCU AE issues a verification request (C-ECHO) and the Image Manager replies with a C-ECHO response (status success).
3. The Verification-SCU AE closes the association with the Image Manager.

4.2.1.3.1.2 Proposed Presentation Contexts

The Verification-SCU AE is capable of proposing the Presentation Contexts shown in the following table:

TABLE 4.2- 8 PROPOSED PRESENTATION CONTEXTS FOR ACTIVITY VERIFY CONNECTION

Presentation Context Table					
Abstract Syntax		Transfer Syntax		Role	Ext. Neg.
Name	UID	Name List	UID List		
Verification	1.2.840.10008.1.1	Implicit VR Little Endian	1.2.840.10008.1.2	SCU	None

4.2.1.3.1.3 SOP Specific Conformance Verification SOP Classes

The Verification-SCU AE provides standard conformance to the Verification Service Class as an SCU.

The behavior of Verification-SCU AE when encountering status codes in a C-ECHO response is summarized in the table below:

TABLE 4.2- 9 VERIFICATION RESPONSE STATUS HANDLING BEHAVIOR

Service Status	Further Meaning	Error Code	Behavior
Success	Success	0000	The Verification-SCU AE judges the remote AE is present and active on the network.

*	*	Any other status code.	The Verification-SCU AE judges the remote AE is not present or not active on the network.
---	---	------------------------	---

4.2.1.4 Association Acceptance Policy

The Verification-SCU AE does not accept any association.

4.2.2 Storage-SCU Application Entity Specification

4.2.2.1 SOP Classes

AWS provides Standard Conformance to the following SOP Classes:

TABLE 4.2- 10 SOP CLASSES FOR THE STORAGE-SCU AE

SOP Class Name	SOP Class UID	SCU	SCP
Computed Radiography Image Storage	1.2.840.10008.5.1.4.1.1.1	Yes	No
Digital Mammography X-Ray Image Storage – For Presentation	1.2.840.10008.5.1.4.1.1.1.2	Yes	No
Digital Mammography X-Ray Image Storage – For Processing	1.2.840.10008.5.1.4.1.1.1.2.1	Yes	No
Breast Tomosynthesis Image Storage	1.2.840.10008.5.1.4.1.1.13.1.3	Yes	No
Key Object Selection Document	1.2.840.10008.5.1.4.1.1.88.59	Yes	No
X-Ray Radiation Dose SR	1.2.840.10008.5.1.4.1.1.88.67	Yes	No

Note : Tomosynthesis (including Reconstructed and S-View) images support the following SOP Class.

Computed Radiography Image Storage

Digital Mammography X-Ray Image Storage - For Presentation

Breast Tomosynthesis Image Storage

4.2.2.2 Association Policies

4.2.2.2.1 General

The DICOM standard application context name for DICOM 3.0 is always proposed:

TABLE 4.2- 11 DICOM APPLICATION CONTEXT FOR THE STORAGE-SCU AE

Application Context Name	1.2.840.10008.3.1.1.1
--------------------------	-----------------------

4.2.2.2.2 Number of Associations

AWS initiates Three Associations at a time for each destination to which a transfer request is being processed in the active job queue list. Three jobs will be active at a time, the other remains pending until the active job is completed or failed.

TABLE 4.2- 12 NUMBER OF ASSOCIATIONS INITIATED FOR THE STORAGE-SCU AE

Maximum number of simultaneous Associations	3
---	---

4.2.2.2.3 Asynchronous Nature

AWS does not support asynchronous communication (multiple outstanding transactions over a single Association).

TABLE 4.2- 13 ASYNCHRONOUS NATURE FOR THE STORAGE-SCU AE

Maximum number of outstanding asynchronous transactions	1
---	---

4.2.2.2.4 Implementation Identifying Information

The implementation information for this Application Entity is:

TABLE 4.2- 14 DICOM IMPLEMENTATION CLASS AND VERSION FOR THE STORAGE-SCU AE

Implementation Class UID	1.2.392.200036.9125.5342.1
Implementation Version Name	A00

4.2.2.3 Association Initiation Policy

4.2.2.3.1 Activity – Send Images & Documents

4.2.2.3.1.1 Description and Sequencing of Activities

The AWS will acquire images/documents and send those images/documents automatically to the pre-set remote host or select images/documents from the list of images/documents thus stored and send them to the specified destination.

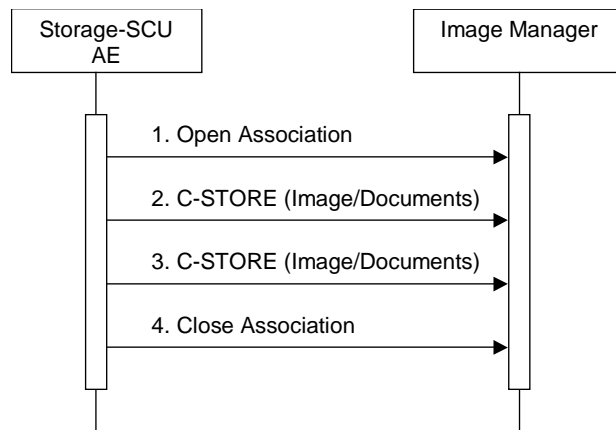

FIGURE 4.2- 4 SEQUENCING OF ACTIVITY – SEND IMAGES & DOCUMENTS

A possible sequence of interactions between the Storage-SCU AE and an Image Manager (e.g. a storage or archive device supporting the Storage SOP Classes as an SCP) is illustrated in Figure above:

1. The Storage-SCU AE opens an association with the Image Manager
2. An acquired image/document is transmitted to the Image Manager using a C-STORE request and the Image Manager replies with a C-STORE response (status success).
3. Another acquired image/document is transmitted to the Image Manager using a C-STORE request and the Image Manager replies with a C-STORE response (status success).

4. The Storage-SCU AE closes the association with the Image Manager.

NOTE: Many other message sequences are possible depending on the number of images to be stored. Storage-SCU AE doesn't send images and documents together.

4.2.2.3.1.2 Proposed Presentation Contexts

The Storage-SCU AE is capable of proposing the Presentation Contexts shown in the following table:

TABLE 4.2- 15 PROPOSED PRESENTATION CONTEXTS FOR ACTIVITY SEND IMAGES

Presentation Context Table					
Abstract Syntax		Transfer Syntax		Role	Ext. Neg.
Name	UID	Name List	UID List		
Computed Radiography Image Storage	1.2.840.10008.5.1.4.1.1.1	Implicit VR Little Endian	1.2.840.10008.1.2	SCU	None
		Explicit VR Little Endian	1.2.840.10008.1.2.1		
		JPEG Lossless Hierarchical First-Order Prediction	1.2.840.10008.1.2.4.70		
Digital Mammography X-Ray Image Storage – For Presentation	1.2.840.10008.5.1.4.1.1.1.2	Implicit VR Little Endian	1.2.840.10008.1.2	SCU	None
		Explicit VR Little Endian	1.2.840.10008.1.2.1		
		JPEG Lossless Hierarchical First-Order Prediction	1.2.840.10008.1.2.4.70		
Digital Mammography X-Ray Image Storage – For Processing	1.2.840.10008.5.1.4.1.1.1.2.1	Implicit VR Little Endian	1.2.840.10008.1.2	SCU	None
		Explicit VR Little Endian	1.2.840.10008.1.2.1		
		JPEG Lossless Hierarchical First-Order Prediction	1.2.840.10008.1.2.4.70		
Breast Tomosynthesis Image Storage	1.2.840.10008.5.1.4.1.1.13.1.3	Implicit VR Little Endian	1.2.840.10008.1.2	SCU	None
		Explicit VR Little Endian	1.2.840.10008.1.2.1		
		JPEG Lossless Hierarchical First-Order Prediction	1.2.840.10008.1.2.4.70		
Key Object Selection Document	1.2.840.10008.5.1.4.1.1.88.59	Implicit VR Little Endian	1.2.840.10008.1.2	SCU	None
X-Ray Radiation Dose SR	1.2.840.10008.5.1.4.1.1.88.67	Implicit VR Little Endian	1.2.840.10008.1.2	SCU	None

NOTE: Multiple Transfer Syntax can be set in an Abstract Syntax, however only one setting that is set first is valid.

4.2.2.3.1.3 SOP Specific Conformance for Storage SOP Classes

This implementation tries to send all images/documents that belong to a single study over a single association. If some of the images/documents could not be sent successfully, this implementation will terminate the association and try to resend all images over another association.

The behavior of Storage-SCU AE when encountering status codes in a C-STORE response is summarized in the Table below:

TABLE 4.2- 16 STORAGE C-STORE RESPONSE STATUS HANDLING BEHAVIOR

Service Status	Further Meaning	Error Code	Behavior
Success	Success	0000	The SCP has successfully stored the SOP Instance. If all SOP Instances in a send job have status success then the job is marked as complete.
*	*	Any other status code.	The Association is aborted using A-ABORT and the send job is marked as failed. The status code is logged and the job failure is reported to the user via the job control application.

4.2.2.4 Association Acceptance Policy

The Storage-SCU AE does not accept any association.

4.2.3 Storage Commitment-SCU Application Entity Specification

4.2.3.1 SOP Classes

AWS provides Standard Conformance to the following SOP Classes:

TABLE 4.2- 17 SOP CLASSES FOR THE STORAGE COMMITMENT-SCU AE

SOP Class Name	SOP Class UID	SCU	SCP
Storage Commitment Push Model	1.2.840.10008.1.20.1	Yes	No

4.2.3.2 Association Policies

4.2.3.2.1 General

The DICOM standard application context name for DICOM 3.0 is always proposed:

TABLE 4.2- 18 DICOM APPLICATION CONTEXT FOR THE STORAGE COMMITMENT-SCU AE

Application Context Name	1.2.840.10008.3.1.1.1
--------------------------	-----------------------

4.2.3.2.2 Number of Associations

The Storage Commitment-SCU AE can initiate up to three associations at a time.

TABLE 4.2- 19 NUMBER OF ASSOCIATIONS INITIATED FOR THE STORAGE COMMITMENT-SCU AE

Maximum number of simultaneous associations	3
---	---

The Storage Commitment SCU AE accepts associations to receive N-EVENT-REPORT notifications for the Storage Commitment Push Model SOP Class.

TABLE 4.2- 20 NUMBER OF ASSOCIATIONS ACCEPTED FOR THE STORAGE COMMITMENT-SCU AE

Maximum number of simultaneous associations	3
---	---

4.2.3.2.3 Asynchronous Nature

The Storage Commitment-SCU AE does not support asynchronous communication (multiple outstanding transactions over a single association).

TABLE 4.2- 21 ASYNCHRONOUS NATURE FOR THE STORAGE COMMITMENT-SCU AE

Maximum number of outstanding asynchronous transactions	1
---	---

4.2.3.2.4 Implementation Identifying Information

TABLE 4.2- 22 DICOM IMPLEMENTATION CLASS AND VERSION FOR THE STORAGE COMMITMENT- SCU AE

Implementation Class UID	1.2.392.200036.9125.5342.1
Implementation Version Name	A00

4.2.3.3 Association Initiation Policy

4.2.3.3.1 Activity – Commit Sent Images

4.2.3.3.1.1 Description and Sequencing of Activities

If the remote AE is configured as a Storage Commitment-SCP AE, the Storage Commitment-SCU AE will, after all images have been sent, transmit a single storage commitment request (N-ACTION). Upon receiving the N-ACTION response the Storage Commitment-SCU AE will release the association. The notification of storage commitment (N-EVENT-REPORT) will be received over a separate association.

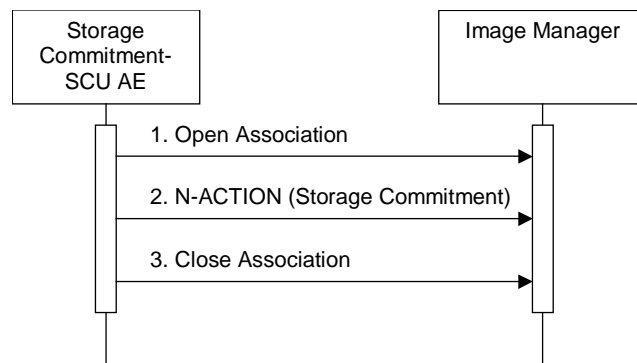

FIGURE 4.2- 5 SEQUENCING OF ACTIVITY – COMMIT SENT IMAGES

A possible sequence of interactions between the Storage Commitment-SCU AE and an Image Manager (e.g. a storage or archive device supporting the Storage Commitment SOP Classes as an SCP) is illustrated in the Figure above:

1. The Storage Commitment-SCU AE opens an association with the Image Manager.
2. A storage commitment request (N-ACTION) is transmitted to the Image Manager to obtain storage commitment of previously transmitted images. The Image Manager replies with an N-ACTION response indicating the request has been received and is being processed.
3. The Storage Commitment-SCU AE closes the association with the Image Manager.

NOTE: The N-EVENT-REPORT will be sent over a separate association initiated by the Image Manager. (see Section 4.2.2.4.1)

4.2.3.3.1.2 Proposed Presentation Contexts

The Storage Commitment-SCU AE is capable of proposing the Presentation Contexts shown in the following table:

TABLE 4.2- 23 PROPOSED PRESENTATION CONTEXTS FOR ACTIVITY COMMIT SEND IMAGES

Presentation Context Table					
Abstract Syntax		Transfer Syntax		Role	Ext. Neg.
Name	UID	Name List	UID List		
Storage Commitment Push Model	1.2.840.10008.1.20.1	Implicit VR Little Endian	1.2.840.10008.1.2	SCU	None

4.2.3.3.1.3 SOP Specific Conformance for Storage Commitment SOP Classes

The Storage Commitment-SCU AE provides standard conformance to the Storage Commitment Service Class as an SCU. The Storage Commitment-SCU AE will request storage commitment for instances of the Storage SOP Classes if the remote AE is configured as a Storage Commitment-SCP AE and a presentation context for the Storage Commitment Push Model has been accepted.

The behavior of Storage Commitment-SCU AE when encountering status codes in an N-ACTION response is summarized in the table below:

TABLE 4.2- 24 STORAGE COMMITMENT N-ACTION RESPONSE STATUS HANDLING BEHAVIOR

Service Status	Further Meaning	Error Code	Behavior
Success	Success	0000	The request for storage commitment is considered successfully sent. A timer is started which will expire if no N-EVENT-REPORT for the Transaction UID is received within a configurable timeout period.
*	*	Any other status code.	The association is aborted and the request for storage commitment is marked as failed.

4.2.3.4 Association Initiation Policy

4.2.3.4.1 Activity – Receive Storage Commitment

4.2.3.4.1.1 Description and Sequencing of Activities

The Storage Commitment-SCU AE will accept associations in order to receive responses to a storage commitment request.

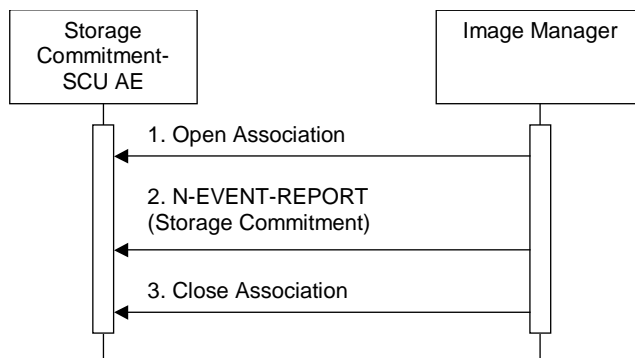

FIGURE 4.2- 6 SEQUENCING OF ACTIVITY – RECEIVE STORAGE COMMITMENT

A possible sequence of interactions between the Storage Commitment-SCU AE and an Image Manager (e.g. a storage or archive device supporting the Storage Commitment SOP Classes as an SCP) is illustrated in the Figure above:

1. The Image Manager opens an association with the Storage Commitment-SCU AE.
2. The Image Manager sends an N-EVENT-REPORT request notifying the Storage-SCU AE of the status of a previous storage commitment request. The Storage-SCU AE replies with an N-EVENT-REPORT response confirming receipt.
3. The Image Manager closes an association with the Storage Commitment-SCU AE.

4.2.3.4.1.2 Proposed Presentation Contexts

The Presentation Contexts shown in the following table are acceptable to the Storage Commitment-SCU AE:

TABLE 4.2- 25 PROPOSED PRESENTATION CONTEXTS FOR ACTIVITY RECEIVE STORAGE COMMITMENT

Presentation Context Table					
Abstract Syntax		Transfer Syntax		Role	Ext. Neg.
Name	UID	Name List	UID List		
Storage Commitment Push Model	1.2.840.10008.1.20.1	Implicit VR Little Endian	1.2.840.10008.1.2	SCU	None

4.2.3.4.1.3 SOP Specific Conformance for Storage Commitment SOP Classes

The behavior of Storage Commitment-SCU AE when receiving Event Types within the N-EVENT-REPORT is summarized in the Table below.

TABLE 4.2- 26 STORAGE COMMITMENT N-EVENT-REPORT BEHAVIOR

Event Type Name	Event Type ID	Behavior
Storage Commitment Request Successful	1	The Storage Commitment SCU AE permits the operator(s) to delete the Referenced SOP Instances under Referenced SOP Sequence (0008,1199), or deletes the Instances from the local database automatically.
Storage Commitment Request Complete – Failures Exist	2	The Storage Commitment SCU AE requests the Storage SCU AE to send the Referenced SOP Instances under Failed SOP Sequence (0008,1198).

The reasons for returning specific status codes in an N-EVENT-REPORT response are summarized in the table below.

TABLE 4.2- 27 STORAGE COMMITMENT N-EVENT-REPORT RESPONSE STATUS REASONS

Service Status	Further Meaning	Error Code	Reasons
Success	Success	0000	The storage commitment result has been successfully received.
Failure	Unrecognized Operation	0211H	The Transaction UID in the N-EVENT-REPORT request is not recognized (was never issued within an N-ACTION request).
Failure	Resource Limitation	0213H	The Transaction UID in the N-EVENT-REPORT request has expired (no N-EVENT-REPORT was received within a configurable time limit).

Failure	No Such Event Type	0113H	An invalid Event Type ID was supplied in the N-EVENT-REPORT request.
Failure	Processing Failure	0110H	An internal error occurred during processing of the N-EVENT-REPORT. A short description of the error will be returned in Error Comment (0000,0902).
Failure	Invalid Argument Value	0115H	One or more SOP Instance UIDs with the Referenced SOP Sequence (0008,1199) or Failed SOP Sequence (0008,1198) was not included in the Storage Commitment Request associated with this Transaction UID. The unrecognized SOP Instance UIDs will be returned within the Event Information of the N-EVENT-REPORT response.
*	*	Any other status code.	The storage commitment result has some error, so result has not been successfully received.

4.2.4 MWM-SCU Application Entity Specification

4.2.4.1 SOP Classes

AWS provides Standard Conformance to the following SOP Classes:

TABLE 4.2- 28 SOP CLASSES FOR THE MWM-SCU AE

SOP Class Name	SOP Class UID	SCU	SCP
Modality Worklist Information Model – FIND	1.2.840.10008.5.1.4.31	Yes	No

4.2.4.2 Association Policies

4.2.4.2.1 General

The DICOM standard application context name for DICOM 3.0 is always proposed:

TABLE 4.2- 29 DICOM APPLICATION CONTEXT FOR THE MWM-SCU AE

Application Context Name	1.2.840.10008.3.1.1.1
--------------------------	-----------------------

4.2.4.2.2 Number of Associations

AWS initiates one Association at a time for each destination to which a transfer request is being processed in the active job queue list. Only one job will be active at a time, the other remains pending until the active job is completed or failed.

TABLE 4.2- 30 NUMBER OF ASSOCIATIONS INITIATED FOR THE MWM-SCU AE

Maximum number of simultaneous Associations	1
---	---

4.2.4.2.3 Asynchronous Nature

AWS does not support asynchronous communication (multiple outstanding transactions over a single Association).

TABLE 4.2- 31 ASYNCHRONOUS NATURE FOR THE MWM-SCU AE

Maximum number of outstanding asynchronous transactions	1
---	---

4.2.4.2.4 Implementation Identifying Information

The implementation information for this Application Entity is:

TABLE 4.2- 32 DICOM IMPLEMENTATION CLASS AND VERSION FOR THE MWM-SCU AE

Implementation Class UID	1.2.392.200036.9125.5342.1
Implementation Version Name	A00

4.2.4.3 Association Initiation Policy

4.2.4.3.1 Activity – Update Worklist

4.2.4.3.1.1 Description and Sequencing of Activities

The request for a Update Worklist is initiated by user interaction, i.e. pressing the buttons “Refresh” or automatically at specific time intervals, configurable by the user.

Upon initiation of the request, the MWM-SCU AE will build an Identifier for the C-FIND request, will initiate an Association to send the request and will wait for Worklist responses. After retrieval of all responses, the MWM-SCU AE will access the local database to add or update patient demographic data. The results will be displayed in a list.

The will initiate an Association in order to issue a C-FIND request according to the Modality Worklist Information Model.

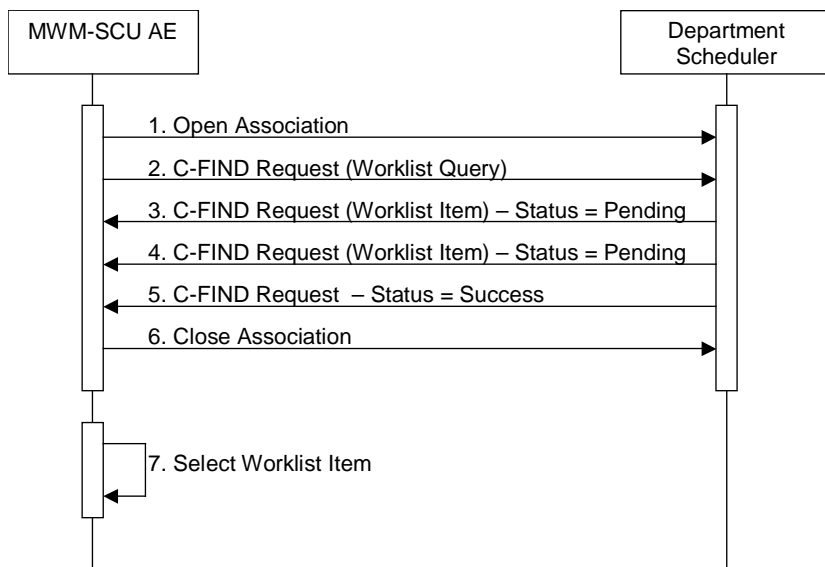

FIGURE 4.2- 7 SEQUENCING OF ACTIVITY – UPDATE WORKLIST

A possible sequence of interactions between the MWM-SCU AE and a Departmental Scheduler (e.g. a device such as a RIS or HIS which supports the Modality Worklist SOP Class as an SCP) is illustrated in the Figure above:

1. The MWM-SCU AE opens an association with the Department Scheduler.
2. The MWM-SCU AE sends a C-FIND request to the Department Scheduler containing the Worklist Query attributes.
3. The Department Scheduler returns a C-FIND response containing the requested attributes of the first matching worklist item.
4. The Departmental Scheduler returns another C-FIND response containing the requested attributes of the second matching Worklist Item.
5. The Department Scheduler returns another C-FIND response with status Success indicating that no further matching worklist items exist. This example assumes that only 2 worklist items match the Worklist Query.
6. The MWM-SCU AE closes the association with the Department Scheduler.
7. The user selects a worklist item from the Worklist and prepares to acquire new images.

4.2.4.3.1.2 Proposed Presentation Contexts

The MWM-SCU AE is capable of proposing the Presentation Contexts shown in the following table:

TABLE 4.2- 33 PROPOSED PRESENTATION CONTEXTS FOR ACTIVITY UPDATE WORKLIST

Presentation Context Table					
Abstract Syntax		Transfer Syntax		Role	Ext. Neg.
Name	UID	Name List	UID List		
Modality Worklist Information Model – FIND	1.2.840.10008.5.1.4.31	Implicit VR Little Endian	1.2.840.10008.1.2	SCU	None

4.2.4.3.1.3 SOP Specific Conformance for Modality Worklist SOP Classes

The MWM-SCU AE provides standard conformance to the Modality Worklist SOP Class as an SCU.

The behavior of the MWM-SCU AE when encountering status codes in a Modality Worklist C-FIND response is summarized in the table below.

TABLE 4.2- 34 MODALITY WORKLIST C-FIND RESPONSE STATUS HANDLING BEHAVIOR

Service Status	Further Meaning	Error Code	Behavior
Success	Success	0000	The SCP has completed the matches. Worklist items are available for display or further processing.
*	*	Any other status code.	The association is aborted using A-ABORT and the status meaning is logged.

Acquired images will always use the Study Instance UID specified for the Scheduled Procedure Step (if available). If an acquisition is unscheduled, a Study Instance UID will be generated locally.

The table below provides a description of the MWM-SCU AE Worklist Request Identifier and specifies the attributes that are copied into the images. Unexpected attributes returned in a C-FIND response are ignored.

TABLE 4.2- 35 WORKLIST REQUEST IDENTIFIER

Module Name Attribute Name	Tag	VR	M	R	D	IOD
SOP Common						
Specific Character Set	(0008,0005)	CS		x		x
Scheduled Procedure Step						
Scheduled Procedure Step Sequence	(0040,0100)	SQ		x		
>Scheduled Procedure Step ID	(0040,0009)	SH		x		x
>Scheduled Station AE Title	(0040,0001)	AE	S	x		
>Scheduled Procedure Step Start Data	(0040,0002)	DA	S/R	x		
>Scheduled Procedure Step Start Time	(0040,0003)	TM		x		
>Scheduled Performing Physician's Name	(0040,0006)	PN		x		
>Scheduled Procedure Step Description	(0040,0007)	LO		x		x
>Scheduled Protocol Code Sequence	(0040,0008)	SQ		x		x
>>Code Value	(0008,0100)	SH		x		x
>>Coding Scheme Designator	(0008,0102)	SH		x		x
>>Coding Scheme Version	(0008,0103)	SH		x		x

>>Code Meaning	(0008,0104)	LO		x		x
>Modality	(0008,0060)	CS	S	x		x
Requested Procedure						
Requested Procedure ID	(0040,1001)	SH	S	x		
Reason for Requested Procedure Code Sequence	(0040,100A)	SQ	x			
>Code Value	(0008,0100)	SH	x			
>Coding Scheme Designator	(0008,0102)	SH	x			
>Coding Scheme Version	(0008,0103)	SH	x			
>Code Meaning	(0008,0104)	LO	x			
Requested Procedure Code Sequence	(0032,1064)	SQ		x		
>Code Value	(0008,0100)	SH		x		
>Coding Scheme Designator	(0008,0102)	SH		x		
>Coding Scheme Version	(0008,0103)	SH		x		
>Code Meaning	(0008,0104)	LO		x		
Study Instance UID	(0020,000D)	UI		x		x
Referenced Study Sequence	(0008,1110)	SQ		x		x
>Referenced SOP Class UID	(0008,1150)	UI		x		x
>Referenced SOP Instance UID	(0008,1155)	UI		x		x
Requested Procedure Description	(0032,1060)	LO		x		
Names of Intended Recipients of Results	(0040,1010)	PN		x		
Imaging Service Request						
Referring Physician's Name	(0008,0090)	PN		x		
Referring Physician	(0032,1032)	PN		x	x	
Requesting Service	(0032,1033)	LO		x	x	
Accession Number	(0008,0050)	SH	S	x	x	x
Order Enterer's Location	(0040,2009)	SH		x		
Visit Identification						
Visit Status						
Visit Relationship						
Referenced Patient Sequence	(0008,1120)	SQ		x		
>Referenced SOP Class UID	(0008,1150)	UI		x		
>Referenced SOP Instance UID	(0008,1155)	UI		x		
Visit Admission						
Patient Relationship						
Patient Identification						
Patient's Name	(0010,0010)	PN	S/*	x	x	x
Patient ID	(0010,0020)	LO	S	x	x	x
Other Patient IDs	(0010,1000)	LO		x		
Patient Demographic						
Patients Birth Date	(0010,0030)	DA		x	x	x
Patient's Sex	(0010,0040)	CS		x	x	x
Ethnic Group	(0010,2160)	SH		x		
Patient Comments	(0010,4000)	LT		x	x	
Patient Medical						
Patient State	(0038,0500)	LO		x		
Pregnancy Status	(0010,21C0)	US		x	x	

Additional Patient History	(0010,21B0)	LT		x		
Radiation Dose (Extended)						
Radiation Dose Sequence	(0040,030E)	SQ		x		
>Exposure Type	(0018,115A)	CS		x		
>KVp	(0018,0060)	DS		x		
>X-ray Tube Current in μ A	(0018,8151)	DS		x		
>Exposure Time	(0018,1150)	IS		x		
>Filter Type	(0018,1160)	LO		x		
>Filter Material	(0018,7050)	CS		x		
General Study (Extended)						
Study Description	(0008,1030)	LO		x		
Image Acquisition Results (Extended)						
Study ID	(0020,0010)	SH		x		
Basic Film Session Presentation (Extended)						
Number of Copies	(2000,0010)	IS		x		
Private						
Distribution Code	(0009,xx90)	ST		x		

The above table should be read as follows:

- Module Name: The name of the associated module for supported worklist attributes.
- Attribute Name: Attributes supported to build the MWM-SCU AE Worklist Request Identifier.
- Tag: DICOM tag for this attribute.
- VR: DICOM VR for this attribute.
- M: Matching keys for (automatic) Worklist Update. An "S" will indicate that the MWM-SCU AE will supply an attribute value for Single Value Matching, an "R" will indicate Range Matching and a "*" will denote wildcard matching.
- R: Return keys. An "x" will indicate that the MWM-SCU AE will supply this attribute as Return Key with zero length for Universal Matching.
- D: Displayed keys. An "x" indicates that this worklist attribute is displayed to the user during a patient registration. For example, Patient Name will be displayed when registering the patient prior to an examination.
- IOD: An "x" indicates that this worklist attribute is included into all Object Instances created during performance of the related Procedure Step.

4.2.4.4 Association Acceptance Policy

The MWM-SCU AE does not accept any association.

4.2.5 MPPS-SCU Application Entity Specification

4.2.5.1 SOP Classes

AWS provides Standard Conformance to the following SOP Classes:

TABLE 4.2- 36 SOP CLASSES FOR THE MPPS-SCU AE

SOP Class Name	SOP Class UID	SCU	SCP
Modality Performed Procedure Step	1.2.840.10008.3.1.2.3.3	Yes	No

4.2.5.2 Association Policies

4.2.5.2.1 General

The DICOM standard application context name for DICOM 3.0 is always proposed:

TABLE 4.2- 37 DICOM APPLICATION CONTEXT FOR THE MPPS-SCU AE

Application Context Name	1.2.840.10008.3.1.1.1
--------------------------	-----------------------

4.2.5.2.2 Number of Associations

AWS initiates one Association at a time for each destination to which a transfer request is being processed in the active job queue list. Only one job will be active at a time, the other remains pending until the active job is completed or failed.

TABLE 4.2- 38 NUMBER OF ASSOCIATIONS INITIATED FOR THE MPPS-SCU AE

Maximum number of simultaneous Associations	1
---	---

4.2.5.2.3 Asynchronous Nature

AWS does not support asynchronous communication (multiple outstanding transactions over a single Association).

TABLE 4.2- 39 ASYNCHRONOUS NATURE FOR THE MPPS-SCU AE

Maximum number of outstanding asynchronous transactions	1
---	---

4.2.5.2.4 Implementation Identifying Information

The implementation information for this Application Entity is:

TABLE 4.2- 40 DICOM IMPLEMENTATION CLASS AND VERSION FOR THE MPPS-SCU AE

Implementation Class UID	1.2.392.200036.9125.5342.1
Implementation Version Name	A00

4.2.5.3 Association Initiation Policy

4.2.5.3.1 Activity – Acquire Images

4.2.5.3.1.1 Description and Sequencing of Activities

The MPPS-SCU AE performs the creation of an MPPS instance automatically when the user selects and starts a worklist item. Further updates on the MPPS data can be performed when the user completes the acquisition.

The MPPS-SCU AE will initiate an association to issue an:

- N-CREATE request according to the CREATE Modality Performed Procedure Step SOP Instance operation, or an:

- N-SET request to update the contents and state of the MPPS according to the SET Modality Performed Procedure Step Information operation.

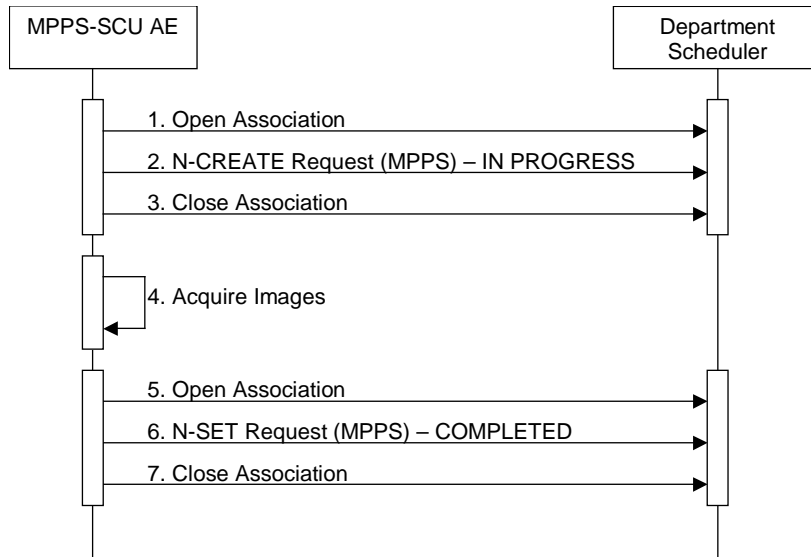

FIGURE 4.2- 8 SEQUENCING OF ACTIVITY – ACQUIRE IMAGES

A possible sequence of interactions between the MPPS SCU AE and a Department Scheduler (e.g. a device such as a RIS or HIS which supports the MPPS SOP Class as an SCP) is illustrated in the Figure above:

1. The MPPS-SCU AE opens an association with the Department Scheduler.
2. The MPPS-SCU AE sends an N-CREATE request to the Department Scheduler to create an MPPS instance with status of “IN PROGRESS” and create all necessary attributes. The Department Scheduler acknowledges the MPPS creation with an N-CREATE response (status success).
3. The MPPS-SCU AE closes the association with the Department Scheduler.
4. All images are acquired and stored in the local database.
5. The MPPS-SCU AE opens an association with the Department Scheduler.
6. The MPPS-SCU AE sends an N-SET request to the Department Scheduler to update the MPPS instance with status of “COMPLETED” and set all necessary attributes. The Department Scheduler acknowledges the MPPS update with an N-SET response (status success).
7. The MPPS-SCU AE closes the association with the Department Scheduler.

4.2.5.3.1.2 Proposed Presentation Contexts

The MPPS-SCU AE is capable of proposing the Presentation Contexts shown in the following table:

TABLE 4.2- 41 PROPOSED PRESENTATION CONTEXTS FOR ACQUIRE IMAGES

Presentation Context Table					
Abstract Syntax		Transfer Syntax		Role	Ext. Neg.
Name	UID	Name List	UID List		
Modality Performed Procedure Step	1.2.840.10008.3.1.2.3.3	Implicit VR Little Endian	1.2.840.10008.1.2	SCU	None

4.2.5.3.1.3 SOP Specific Conformance for MPPS7 SOP Classes

The MPPS-SCU AE provides standard conformance to the Modality Performed Procedure Step SOP Class as an SCU.

The behavior of the MPPS-SCU AE when encountering status codes in an MPPS N-CREATE or N-SET response is summarized in the table below.

TABLE 4.2- 42 MPPS N-CREATE / N-SET RESPONSE HANDLING BEHAVIOR

Service Status	Further Meaning	Error Code	Behavior
Success	Success	0000	The SCP has completed the operation successfully.
*	*	Any other status code.	The association is aborted and the MPPS is marked as failed. The status meaning is logged and reported to the user.

The table below provides a description of the MPPS N-CREATE and N-SET request identifiers sent by the MPPS-SCU AE. Empty cells in the N-CREATE and N-SET columns indicate that the attribute is not sent. An “x” indicates that an appropriate value will be sent. A “Zero length” attribute will be sent with zero length.

TABLE 4.2- 43 MPPS N-CREATE / N-SET REQUEST IDENTIFIER

Attribute Name	Tag	VR	N-CREATE	N-SET
Specific Character Set	(0008,0005)	CS	From MWL	
Performed Procedure Step Relationship				
Scheduled Step Attribute Sequence	(0040,0270)	SQ	From MWL	
>Study Instance UID	(0020,000D)	UI	From MWL	
>Referenced Study Sequence	(0008,1110)	SQ	From MWL	
>>Referenced SOP Class UID	(0008,1150)	UI	From MWL	
>>Referenced SOP Instance UID	(0008,1155)	UI	From MWL	
>Accession Number	(0008,0050)	SH	From MWL or User Input	
>Requested Procedure ID	(0040,1001)	SH	From MWL	
>Requested Procedure Description	(0032,1060)	LO	From MWL	
>Scheduled Procedure Step ID	(0040,0009)	SH	From MWL	
>Scheduled Procedure Step Description	(0040,0007)	LO	From MWL	
>Scheduled Protocol Code Sequence	(0040,0008)	SQ	From MWL	
>>Code Value	(0008,0100)	SH	From MWL	
>>Coding Scheme Designator	(0008,0102)	SH	From MWL	
>>Coding Scheme Version	(0008,0103)	SH	From MWL	
>>Code Meaning	(0008,0104)	LO	From MWL	
Patient's Name	(0010,0010)	PN	From MWL or User Input	
Patient ID	(0010,0020)	LO	From MWL or User Input	
Patient's Birth Data	(0010,0030)	DA	From MWL or User Input	
Patient's Sex	(0010,0040)	CS	From MWL or User Input	
Referenced Patient Sequence	(0008,1120)	SQ	From MWL	
>Referenced SOP Class UID	(0008,1150)	UI	From MWL	

>Referenced Instance UID	(0008,1155)	UI	From MWL	
Performed Procedure Step Information				
Performed Procedure Step ID	(0040,0253)	SH	Automatically created.	
Performed Station AE Title	(0040,0241)	AE	MPPS AE Title	
Performed Station Name	(0040,0242)	SH	x	
Performed Location	(0040,0243)	SH	x	
Performed Procedure Step Start Data	(0040,0244)	DA	Actual start date	
Performed Procedure Step Start Time	(0040,0245)	TM	Actual start time	
Performed Procedure Step Status	(0040,0252)	CS	IN PROGRESS	DISCONTINUED or COMPLETED
Performed Procedure Step End Date	(0040,0250)	DA	Zero length	Actual end date
Performed Procedure Step End Time	(0040,0251)	TM	Zero length	Actual end time
Performed Procedure Step Description	(0040,0254)	LO	x	x
Performed Procedure Type Description	(0040,0255)	LO	x	x
Comments on the Performed Procedure Step	(0040,0280)	ST	x	x
Procedure Code Sequence	(0008,1032)	SQ	x	x
>Code Value	(0008,0100)	SH	x	x
>Coding Scheme Designator	(0008,0102)	SH	x	x
>Coding Scheme Version	(0008,0103)	SH	x	x
>Code Meaning	(0008,0104)	LO	x	x
Reason For Performed Procedure Code Sequence	(0040,1012)	SQ		From MWL(0040,100A)
Image Acquisition Results				
Modality	(0008,0060)	SH	From MWL	
Study ID	(0020,0010)	SH	From MWL	
Performed Protocol Code Sequence	(0040,0260)	SQ	From MWL	x
>Code Value	(0008,0100)	SH	From MWL	x
>Coding Scheme Designator	(0008,0102)	SH	From MWL	x
>Coding Scheme Version	(0008,0103)	SH	From MWL	x
>Code Meaning	(0008,0104)	LO	From MWL	x
Performed Series Sequence	(0040,0340)	SQ	x	x
>Series Description	(0008,103E)	LO	x	x
>Retrieve AE Title	(0008,0054)	AE	x	x
>Performed Physician's Name	(0008,1050)	PN	x	x
>Operator's Name	(0008,1070)	PN	x	x
>Protocol Name	(0018,1030)	LO	x	x
>Series Instance UID	(0020,000E)	UI	x	x
>Referenced Image Sequence	(0008,1140)	SQ	x	
>>Referenced SOP Class UID	(0008,1150)	UI	x	
>>Referenced SOP Instance UID	(0008,1155)	UI	x	
>Referenced Non-Image Composite SOP Instance Sequence	(0040,0220)	SQ	x	x
>>Referenced SOP Class UID	(0008,1150)	UI	x	x
>>Referenced SOP Instance UID	(0008,1155)	UI	x	x
X-Ray Acquisition Dose (Extended)				
Radiation Dose Sequence	(0040,030E)	SQ	x	x

>Exposure Type	(0018,115A)	CS	x	x
>KVp (the result value of the actual exposure)	(0018,0060)	DS	x	x
>X-ray Tube Current in μ A (the result value of the actual exposure)	(0018,8151)	DS	x	x
>Exposure Time (the sum of the result values of the pre-exposure and actual exposure) (For FDR-3000AWS, the result value of the actual exposure)	(0018,1150)	IS	x	x
>Filter Type	(0018,1160)	LO	x	x
>Filter Material	(0018,7050)	CS	x	x
Billing and Material Management Codes (Extended)				
Film Consumption Sequence	(0040,0321)	SQ	x	x
>Number of Films	(2100,0170)	IS	x	x
>Film Size ID	(2010,0050)	CS	x	x
Billing Supplies and Devices Sequence	(0040,0324)	SQ	x	x
>Billing Item Sequence	(0040,0296)	SQ	x	x
>>Code Value	(0008,0100)	SH	x	x
>>Coding Scheme Designator	(0008,0102)	SH	x	x
>>Coding Scheme Version	(0008,0103)	SH	x	x
>>Code Meaning	(0008,0104)	LO	x	x
>Quantity Sequence	(0040,0293)	SQ	x	x
>>Quantity	(0040,0294)	DS	x	x
Private				
Exposure Status Sequence	(0019,XXA0)	SQ	x	x
>Distance Source to Detector	(0018,1110)	DS	x	x
>Exposure (the sum of the result values of the pre-exposure and actual exposure) (For FDR-3000AWS, the result value of the actual exposure)	(0018,1152)	IS	x	x
>Exposure in μ As (the sum of the result values of the pre-exposure and actual exposure) (For FDR-3000AWS, the result value of the actual exposure)	(0018,1153)	IS	x	x
>Grid	(0018,1166)	CS	x	x
>Estimated Radiographic Magnification Factor	(0018,1114)	DS	x	x
>Image Area Dose Product	(0018,115E)	DS	x	x
>Anode Target Material	(0018,1191)	CS	x	x
>Body Part Thickness	(0018,11A0)	DS	x	x
>Compression Force	(0018,11A2)	DS	x	x
>Positioner Primary Angle	(0018,1510)	DS	x	x
>Exposure Division Count	(0019,YY71)	IS	x	x
>Exposure Status	(0019,YYA1)	CS	x	x
>Exposure Kind	(0019,YYA2)	CS	x	x
>Entrance Dose	(0040,0302)	US	x	x
>Organ Dose	(0040,0316)	DS	x	x
>Entrance Dose in mGy	(0040,8302)	DS	x	x

4.2.5.4 Association Acceptance Policy

The MWM-SCU AE does not accept any association.

4.2.6 Print-SCU Application Entity Specification

4.2.6.1 SOP Classes

AWS provides Standard Conformance to the following SOP Classes:

TABLE 4.2- 44 META SOP CLASSES FOR THE PRINT-SCU AE

SOP Class Name	SOP Class UID	SCU	SCP
Basic Grayscale Print Management Meta	1.2.840.10008.5.1.1.9	Yes	No

The above Meta SOP Classes are defined by the following set of supported SOP Classes:

TABLE 4.2- 45 SOP CLASSES FOR THE PRINT-SCU AE

SOP Class Name	SOP Class UID	SCU	SCP
Basic Film Session	1.2.840.10008.5.1.1.1	Yes	No
Basic Film Box	1.2.840.10008.5.1.1.2	Yes	No
Basic Grayscale Image Box	1.2.840.10008.5.1.1.4	Yes	No
Basic Color Image Box	1.2.840.10008.5.1.1.4.1	Yes	No
Printer	1.2.840.10008.5.1.1.16	Yes	No

4.2.6.2 Association Policies

4.2.6.2.1 General

The DICOM standard application context name for DICOM 3.0 is always proposed:

TABLE 4.2- 46 DICOM APPLICATION CONTEXT FOR THE PRINT-SCU AE

Application Context Name	1.2.840.10008.3.1.1.1
--------------------------	-----------------------

4.2.6.2.2 Number of Associations

AWS initiates one Association at a time for each destination to which a transfer request is being processed in the active job queue list. Only one job will be active at a time, the other remains pending until the active job is completed or failed.

TABLE 4.2- 47 NUMBER OF ASSOCIATIONS INITIATED FOR THE PRINT-SCU AE

Maximum number of simultaneous Associations	1
---	---

4.2.6.2.3 Asynchronous Nature

AWS does not support asynchronous communication (multiple outstanding transactions over a single Association).

TABLE 4.2- 48 ASYNCHRONOUS NATURE FOR THE PRINT-SCU AE

Maximum number of outstanding asynchronous transactions	1
---	---

4.2.6.2.4 Implementation Identifying Information

The implementation information for this Application Entity is:

TABLE 4.2- 49 DICOM IMPLEMENTATION CLASS AND VERSION FOR THE PRINT-SCU AE

Implementation Class UID	1.2.392.200036.9125.5342.1
Implementation Version Name	A00

4.2.6.3 Association Initiation Policy

4.2.6.3.1 Activity – Film Images

4.2.6.3.1.1 Description and Sequencing of Activities

A user composes images onto film sheets and requests them to be sent to a specific hardcopy device. The user can select the desired film format and number of copies. Each print-job is forwarded to the job queue and processed individually.

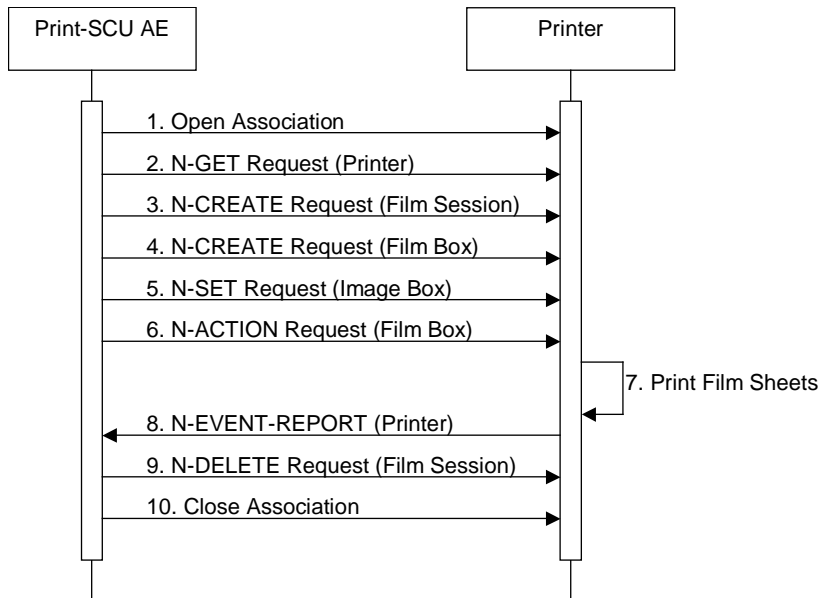

FIGURE 4.2- 9 SEQUENCING OF ACTIVITY – FILM IMAGES

A typical sequence of DIMSE messages sent over an association between Print-SCU AE and a Printer is illustrated in Figure above:

1. The Print-SCU AE opens an association with the Printer.
2. N-GET on the Printer SOP Class is used to obtain current printer status information. If the Printer reports a status of FAILURE, the print-job is switched to a failed state and the user informed.
3. N-CREATE on the Film Session SOP Class creates a Film Session.
4. N-CREATE on the Film Box SOP Class creates a Film Box linked to the Film Session.
5. N-SET on the Image Box SOP Class transfers the contents of the film sheet to the printer.
6. N-ACTION on the Film Box SOP Class instructs the Printer to print the Film Box.
7. The printer prints the requested number of film sheets.
8. The Printer asynchronously reports its status via N-EVENT-REPORT notification (Printer SOP Class). If the Printer reports a status of FAILURE, the print-job is switched to a failed state and the user informed.

- 9. N-DELETE on the Film Session SOP Class deletes the complete Film Session SOP Instance hierarchy.
- 10. The Print SCU AE closes the association with the Printer.

4.2.6.3.1.2 Proposed Presentation Contexts

The Print-SCU AE is capable of proposing the Presentation Contexts shown in the following table:

TABLE 4.2- 50 PROPOSED PRESENTATION CONTEXTS FOR ACTIVITY FILM IMAGES

Presentation Context Table					
Abstract Syntax		Transfer Syntax		Role	Ext. Neg.
Name	UID	Name List	UID List		
Basic Grayscale Print Management Meta	1.2.840.10008.5.1.1.9	Implicit VR Little Endian	1.2.840.10008.1.2	SCU	None

4.2.6.3.1.3 SOP Specific Conformance Printer SOP Class

The Print-SCU AE supports the following DIMSE operations and notifications for the Printer SOP Class:

- N-GET
- N-EVENT-REPORT

Details of the supported attributes and status handling behavior are described in the following subsections.

4.2.6.3.1.3.1 Printer SOP Class Operation (N-GET)

The Print-SCU AE uses the Printer SOP Class N-GET operation to obtain information about the current printer status. The attributes obtained via N-GET are listed in the Table below:

TABLE 4.2- 51 PRINTER SOP CLASS N-GET REQUEST ATTRIBUTES

Attribute Name	Tag	VR	Value	Presence of Value	Source
Printer Status	(2110,0010)	CS	Provided by Printer.	ALWAYS	Printer
Printer Status Info	(2110,0020)	CS	Provided by Printer.	ALWAYS	Printer

The Printer Status information is evaluated as follows:

1. If Printer status (2110,0010) is NORMAL, the print-job continues to be printed.
2. If Printer status (2110,0010) is FAILURE or WARNING, the print-job is marked as failed. The contents of Printer Status Info (2110,0020) is logged and reported to the user via the job control application.

TABLE 4.2- 52 PRINTER SOP CLASS N-GET RESPONSE STATUS HANDLING BEHAVIOR

Service Status	Further Meaning	Error Code	Behavior
Success	Success	0000	The request to get printer status information was success.
*	*	Any other status code.	The Association is aborted using A-ABORT and the print-job is marked as failed. The status meaning is logged and reported to the user.

4.2.6.3.1.3.2 Printer SOP Class Notifications (N-EVENT-REPORT)

The Print-SCU AE is capable of receiving an N-EVENT-REPORT request at any time during an association.

The behavior of Print-SCU AE when receiving Event Types within the N-EVENT-REPORT is summarized in the Table below:

TABLE 4.2- 53 PRINTER SOP CLASS N-EVENT-REPORT BEHAVIOR

Event Type Name	Event Type ID	Behavior
Normal	1	The print-job continues to be printed.
Warning	2	The print-job is marked as failed. The contents of Printer Status Info (2110,0020) is logged and reported to the user via the job-control application.
Failure	3	The print-job is marked as failed. The contents of Printer Status Info (2110,0020) is logged and reported to the user via the job-control application.

The reasons for returning specific status codes in an N-EVENT-REPORT response are summarized in the table below.

TABLE 4.2- 54 PRINTER SOP CLASS N-EVENT-REPORT RESPONSE STATUS REASONS

Service Status	Further Meaning	Error Code	Reasons
Success	Success	0000	The notification event has been successfully received.
*	*	Any other status code.	An error occurred during processing of the N-EVENT-REPORT. A short description of the error will be returned in Error Comment (0000,0902).

4.2.6.3.1.4 SOP Specific Conformance Film Session SOP Class

The Print-SCU AE supports the following DIMSE operations and notifications for the Printer SOP Class:

- N-CREATE
- N-DELETE

Details of the supported attributes and status handling behavior are described in the following subsections.

4.2.6.3.1.4.1 Film Session SOP Class Operation (N-CREATE)

The attributes supplied in an N-CREATE Request are listed in the Table below:

TABLE 4.2- 55 FILM SESSION SOP CLASS N-CREATE REQUEST ATTRIBUTES

Attribute Name	Tag	VR	Value	Presence of Value	Source
Number of Copies	(2000,0010)	IS	0-9	ALWAYS	USER
Print Priority	(2000,0020)	CS	Specifies the priority of the print job. Enumerated Values: HIGH MED LOW	ALWAYS	CONFIG
Medium Type	(2000,0030)	CS	CLEAR FILM BLUE FILM	ALWAYS	CONFIG

Film Destination	(2000,0040)	CS	PROCESSOR BIN_i	ALWAYS	CONFIG
Memory Allocation	(2000,0060)	IS	39219 71438	ALWAYS	CONFIG

The behavior of the Print-SCU AE when encountering status codes in an N-CREATE response is summarized in the table below.

TABLE 4.2- 56 FILM SESSION SOP CLASS N-CREATE RESPONSE HANDLING BEHAVIOR

Service Status	Further Meaning	Error Code	Behavior
Success	Success	0000	The SCP has completed the operation successfully.
*	*	Any other status code.	The Association is aborted using A-ABORT and the print-job is marked as failed. The status meaning is logged and reported to the user.

4.2.6.3.1.4.2 Film Session SOP Class Operation (N-DELETE)

The behavior of the Print-SCU AE when encountering status codes in an N-DELETE response is summarized in the table below.

TABLE 4.2- 57 FILM SESSION SOP CLASS N-DELETE RESPONSE HANDLING BEHAVIOR

Service Status	Further Meaning	Error Code	Behavior
Success	Success	0000	The SCP has completed the operation successfully.
*	*	Any other status code.	The Association is aborted using A-ABORT and the print-job is marked as failed. The status meaning is logged and reported to the user.

4.2.6.3.1.5 SOP Specific Conformance Film Box SOP Class

The Print-SCU AE supports the following DIMSE operations and notifications for the Printer SOP Class:

- N-CREATE
- N-ACTION

Details of the supported attributes and status handling behavior are described in the following subsections.

4.2.6.3.1.5.1 Film Box SOP Class Operation (N-CREATE)

The attributes supplied in an N-CREATE Request are listed in the Table below:

TABLE 4.2- 58 FILM BOX SOP CLASS N-CREATE REQUEST ATTRIBUTES

Attribute Name	Tag	VR	Value	Presence of Value	Source
Image Display Format	(2010,0010)	ST	STANDARD \1,1	ALWAYS	USER
Film Orientation	(2010,0040)	CS	PORTRAIT LANDSCAPE	ALWAYS	USER

Film Size ID	(2010,0050)	CS	8INX10IN, 10INX12IN, 10INX14IN, 11INX14IN, 14INX14IN, 14INX17IN	ALWAYS	USER
Magnification Type	(2010,0060)	CS	REPLICATE, BILINEAR, CUBIC, NONE	ALWAYS	CONFIG
Smoothing Type	(2010,0080)	CS	SHARP SMOOTH MEDIUM	ALWAYS	CONFIG
Border Density	(2010,0100)	CS	BLACK WHITE 0-300	ALWAYS	USER
Max Density	(2010,0130)	US	360,300	ALWAYS	AUTO
Trim	(2010,0140)	CS	NO	ALWAYS	AUTO
Configuration Information	(2010,0150)	ST	"1" - "8", "FINE1" - "FINE8"	ALWAYS	AUTO
Referenced Film Session Sequence	(2010,0500)	SQ		ALWAYS	AUTO
>Referenced SOP Class UID	(0008,1150)	UI	1.2.840.10008.5.1.1.1	ALWAYS	AUTO
>Referenced SOP Instance UID	(0008,1155)	UI	From created Film Session SOP Instance.	ALWAYS	AUTO

The behavior of the Print-SCU AE when encountering status codes in an N-CREATE response is summarized in the table below.

TABLE 4.2- 59 FILM BOX SOP CLASS N-CREATE RESPONSE HANDLING BEHAVIOR

Service Status	Further Meaning	Error Code	Behavior
Success	Success	0000	The SCP has completed the operation successfully.
*	*	Any other status code.	The Association is aborted using A-ABORT and the print-job is marked as failed. The status meaning is logged and reported to the user.

4.2.6.3.1.5.2 Film Box SOP Class Operations (N-ACTION)

An N-ACTION Request is issued to instruct the Print SCP to print the contents of the Film Box. The Action Reply argument in an N-ACTION response is not evaluated.

The behavior of The Print-SCU AE when encountering status codes in an N-ACTION response is summarized in the table below:

TABLE 4.2- 60 FILM BOX SOP CLASS N-ACTION RESPONSE HANDLING BEHAVIOR

Service Status	Further Meaning	Error Code	Behavior
Success	Success	0000	The SCP has completed the operation successfully. The film has been accepted for printing.
*	*	Any other	The Association is aborted using A-ABORT and the print-

		status code.	job is marked as failed. The status meaning is logged and reported to the user.
--	--	--------------	---

4.2.6.3.1.6 SOP Specific Conformance Basic Grayscale Image Box SOP Class

The Print-SCU AE supports the following DIMSE operations and notifications for the Printer SOP Class:

- N-SET

Details of the supported attributes and status handling behavior are described in the following subsections.

4.2.6.3.1.6.1 Basic Grayscale Image Box SOP Class Operation (N-SET)

The attributes supplied in an N-SET Request are listed in the Table below:

TABLE 4.2- 61 BASIC GRAYSCALE IMAGE BOX SOP CLASS N-SET REQUEST ATTRIBUTES

Attribute Name	Tag	VR	Value	Presence of Value	Source
Smoothing Type	(2010,0080)	CS	SHARP SMOOTH MEDIUM	ALWAYS	CONFIG
Max Density	(2010,0130)	US	360,300	ALWAYS	AUTO
Configuration Information	(2010,0150)	ST	"1" - "8", "FINE1" - "FINE8"	ALWAYS	AUTO
Image Position	(2020,0010)	US	1	ALWAYS	AUTO
Requested Image Size	(2020,0030)	DS	Depend on Image Size and Film Format.	ALWAYS	AUTO
Requested Decimate/Crop Behavior	(2020,0040)	CS	"CROP" or with no tags.	ANAP	AUTO
Basic Grayscale Image Sequence	(2020,0110)	SQ		ALWAYS	AUTO
>Samples Per Pixel	(0028,0002)	US	1	ALWAYS	AUTO
Photometric Interpretation	(0028,0004)	CS	MONOCHROME1	ALWAYS	AUTO
Rows	(0028,0010)	US	Depend on Image Size and Film Format.	ALWAYS	AUTO
Columns	(0028,0011)	US	Depend on Image Size and Film Format.	ALWAYS	AUTO
Bits Allocated	(0028,0100)	US	16	ALWAYS	AUTO
Bits Stored	(0028,0101)	US	10,12,14	ALWAYS	AUTO
High Bit	(0028,0102)	US	9,11	ALWAYS	AUTO
Pixel Representation	(0028,0103)	US	0	ALWAYS	AUTO
Pixel Data	(7FE0,0010)	OW		ALWAYS	AUTO

The behavior of the Print-SCU AE when encountering status codes in an N-SET response is summarized in the table below.

TABLE 4.2- 62 BASIC GRAYSCALE IMAGE BOX SOP CLASS N-SET RESPONSE HANDLING BEHAVIOR

Service Status	Further Meaning	Error Code	Behavior
Success	Success	0000	The SCP has completed the operation successfully. Image successfully stored in Image Box.
*	*	Any other status code.	The Association is aborted using A-ABORT and the print-job is marked as failed. The status meaning is logged and reported to the user.

4.2.6.4 Association Acceptance Policy

The Print-SCU AE does not accept any association.

4.2.7 Q/R-SCU Application Entity Specification

4.2.7.1 SOP Classes

AWS provides Standard Conformance to the following SOP Classes:

TABLE 4.2- 63 SOP CLASSES FOR THE Q/R-SCU AE

SOP Class Name	SOP Class UID	SCU	SCP
Study Root Query/Retrieve Information Model - FIND	1.2.840.10008.5.1.4.1.2.2.1	Yes	No
Study Root Query/Retrieve Information Model - MOVE	1.2.840.10008.5.1.4.1.2.2.2	Yes	No

4.2.7.2 Association Policies

4.2.7.2.1 General

The DICOM standard application context name for DICOM 3.0 is always proposed:

TABLE 4.2- 64 DICOM APPLICATION CONTEXT FOR THE Q/R-SCU AE

Application Context Name	1.2.840.10008.3.1.1.1
--------------------------	-----------------------

4.2.7.2.2 Number of Associations

AWS initiates Four Associations at a time for each destination to which a transfer request is being processed in the active job queue list. Four jobs will be active at a time, the other remains pending until the active job is completed or failed.

TABLE 4.2- 65 NUMBER OF ASSOCIATIONS INITIATED FOR THE Q/R-SCU AE

Maximum number of simultaneous Associations	4
---	---

4.2.7.2.3 Asynchronous Nature

AWS does not support asynchronous communication (multiple outstanding transactions over a single Association).

TABLE 4.2- 66 ASYNCHRONOUS NATURE FOR THE Q/R-SCU AE

Maximum number of outstanding asynchronous transactions	1
---	---

4.2.7.2.4 Implementation Identifying Information

The implementation information for this Application Entity is:

TABLE 4.2- 67 DICOM IMPLEMENTATION CLASS AND VERSION FOR THE Q/R-SCU AE

Implementation Class UID	1.2.392.200036.9125.5342.1
Implementation Version Name	A00

4.2.7.3 Association Initiation Policy

4.2.7.3.1 Activity – Query and Retrieve Image

4.2.7.3.1.1 Description and Sequencing of Activities

The Q/R-SCU AE is activated when the user selects a remote node to query and enters some key information, Patient’s Name, Patient ID, Study Date, Accession Number and Modality. The user can select studies, series and images to be retrieved. The images will be received at the Storage-SCP AE.

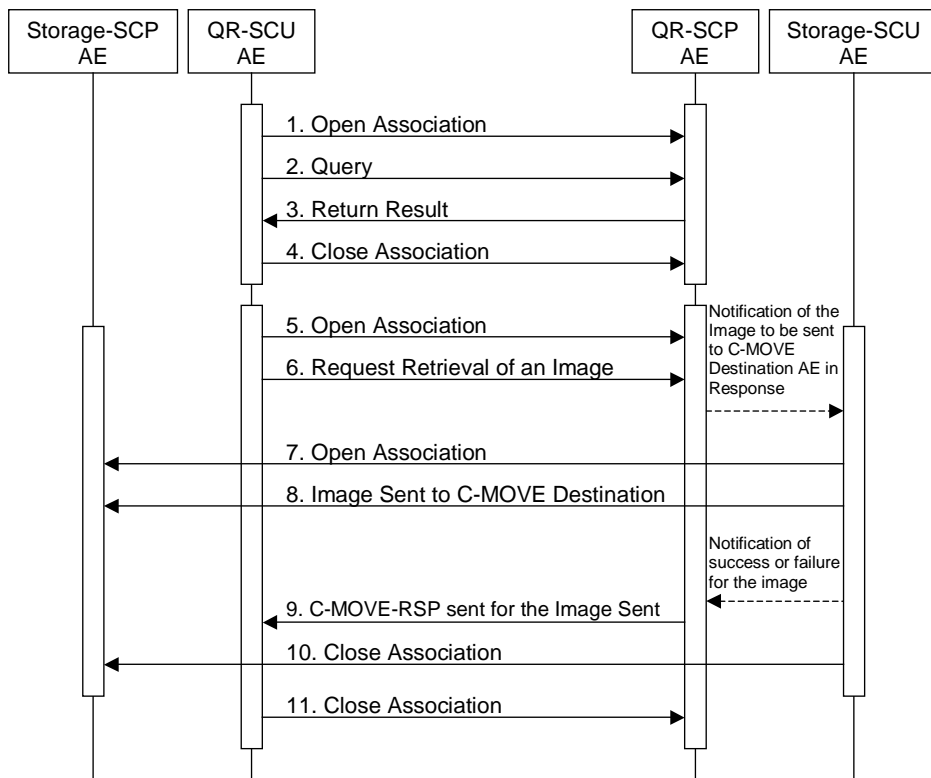

FIGURE 4.2- 10 SEQUENCING OF ACTIVITY – QUERY AND RETRIEVE IMAGE

The following sequencing constraints illustrated in the Figure above:

11. The Q/R-SCU AE opens an association with the Q/R-SCP AE.
12. The Q/R-SCU AE sends a C-FIND-RQ Message.
13. The Q/R-SCP AE returns a C-FIND-RSP Message to the Q/R-SCU AE with matching information. A C-FIND-RSP is sent for each entity matching the identifier specified in the C-FIND-RQ. A final C-FIND-RSP is sent indicating that the matching is complete.

14. The Q/R-SCU AE closes the association.
15. The Q/R-SCU AE opens an association with the Q/R-SCP AE.
16. The Q/R-SCU AE sends a C-MOVE-RQ Message. The Q/R-SCP AE notifies the Storage-SCU AE to send the Composite SOP Instances to the peer C-MOVE Destination AE as indicated in the C-MOVE-RQ.
17. The Storage-SCU AE opens an association with the C-MOVE Destination AE.
18. The Storage-SCU AE sends images to the C-MOVE Destination AE. The Storage-SCU AE indicates to the Q/R-SCP AE whether the transfer succeeded or failed.
19. The Q/R-SCP AE then returns a C-MOVE-RSP indicating this success or failure.
20. The Storage-SCU AE closes the association.
21. The Q/R-SCU AE closes the association.

4.2.7.3.1.2 Proposed Presentation Contexts

The Q/R-SCU AE is capable of proposing the Presentation Contexts shown in the following table:

TABLE 4.2- 68 PROPOSED PRESENTATION CONTEXTS FOR ACTIVITY QUERY AND RETRIEVE IMAGE

Presentation Context Table					
Abstract Syntax		Transfer Syntax		Role	Ext. Neg.
Name	UID	Name List	UID List		
Study Root Query/Retrieve Information Model - FIND	1.2.840.10008.5.1.4.1.2.2.1	Implicit VR Little Endian	1.2.840.10008.1.2	SCU	None
Study Root Query/Retrieve Information Model - MOVE	1.2.840.10008.5.1.4.1.2.2.2	Implicit VR Little Endian	1.2.840.10008.1.2	SCU	None

4.2.7.3.1.3 SOP Specific Conformance Study Root Query/Retrieve Information Model - FIND SOP Classes

The Q/R-SCU AE provides standard conformance to the Q/R Find (=Study Root Query/Retrieve Information Model – FIND) SOP Class as an SCU.

The behavior of the Q/R-SCU AE when encountering status codes in a Q/R C-FIND response is summarized in the table below.

TABLE 4.2- 69 Q/R C-FIND RESPONSE STATUS HANDLING BEHAVIOR

Service Status	Further Meaning	Error Code	Behavior
Success	Success	0000	The SCP has completed the matches. Worklist items are available for display or further processing.
Pending	Matches are continuing - Current Match is supplied and any Optional Key were supported in the same manner as	FF00	Behavior is continuing to receive the matching result.

	Required Keys		
Pending	Matches are continuing - Warning that one or more Optional Keys were not supported for existence and/or matching for this Identifier	FF01	Behavior is continuing.
Cancel	Matching terminated due to Cancel request	FE01	Behavior is cancelled.
*	*	Any other status code.	The association is aborted using A-ABORT and the status meaning is logged.

All queries are initiated at the highest level of the information model (the STUDY level), and then for each response received, recursively repeated at the next lower levels (the SERIES and then IMAGE levels), in order to completely elucidate the “tree” of instances available on the remote AE. The table below provides a description of the Q/R-SCU AE C-FIND Request Identifier.

TABLE 4.2- 70 STUDY ROOT REQUEST IDENTIFIER FOR C-FIND

Name	Tag	Types of Matching
SOP Common		
Specific Character Set	(0008,0005)	NONE
Query/Retrieve Level	(0008,0052)	NONE
Retrieve AE Title	(0008,0054)	NONE
Study Level		
Patient’s Name	(0010,0010)	S,*;U
Patient ID	(0010,0020)	S,*;U
Patient Birth Date	(0010,0030)	NONE
Patient Sex	(0010,0040)	NONE
Study Date	(0008,0020)	R,U
Study Time	(0008,0030)	NONE
Accession Number	(0008,0050)	S,*;U
Study ID	(0020,0010)	NONE
Modalities In Study (※)	(0008,0061)	S,*;U/ NONE
Study Instance UID	(0020,000D)	NONE
Series Level		
Modality	(0008,0060)	S,U
Series Number	(0020,0011)	NONE
Series Instance UID	(0020,000E)	NONE
Image Level		
SOP Instance UID	(0008,0018)	U
Acquisition Device Processing Description	(0018,1400)	NONE
Instance Number	(0020,0013)	NONE

The tables should be read as follows:

Types of Matching: The types of Matching supported by the Q/R-SCU AE. A "S" indicates the identifier attribute can specify Single Value Matching, an "R" will indicate Range Matching, a "*" will denote wildcard matching, an 'U' will indicate universal matching. "NONE" indicates that no matching is supported, but that values for this Element in the database can be returned.

※ When only using Referral Viewing Function(Optional), Modalities In Study (0008,0061) is matching supported by the Q/R-SCU AE.

4.2.7.3.1.4 SOP Specific Conformance Study Root Query/Retrieve Information Model - MOVE SOP Classes

The Q/R-SCU AE provides standard conformance to the Q/R Move (=Study Root Query/Retrieve Information Model – MOVE) SOP Class as an SCU.

The behavior of the Q/R-SCU AE when encountering status codes in a Q/R C-MOVE response is summarized in the table below.

TABLE 4.2- 71 Q/R C-MOVE RESPONSE STATUS HANDLING BEHAVIOR

Service Status	Further Meaning	Error Code	Behavior
Success	Success	0000	The Storage-SCP AE has successfully received the SOP Instance. If all SOP Instances in a move job have status success then the job is marked as complete.
Pending	SubOperations are Continuing	FF00	Behavior is continuing to receive the SOP Instance until complete.
Warning	SubOperations Complete - One or More Failure	B000	Behavior ends normally, but logs events.
Cancel	SubOperations terminated due to Cance	FE00	Behavior is cancelled.
*	*	Any other status code.	The association is aborted using A-ABORT and the status meaning is logged.

4.2.7.4 Association Acceptance Policy

The Q/R-SCU AE does not accept any association.

4.2.8 Storage-SCP Application Entity Specification

4.2.8.1 SOP Classes

AWS provides Standard Conformance to the following SOP Classes:

TABLE 4.2- 72 SOP CLASSES FOR THE STORAGE-SCP AE

SOP Class Name	SOP Class UID	SCU	SCP
Computed Radiography Image Storage	1.2.840.10008.5.1.4.1.1.1	No	Yes
Digital Mammography X-Ray Image Storage – For Presentation	1.2.840.10008.5.1.4.1.1.2	No	Yes

Digital Mammography X-Ray Image Storage – For Processing	1.2.840.10008.5.1.4.1.1.1.2.1	No	Yes
Digital X-ray Image Storage – For Presentation※	1.2.840.10008.5.1.4.1.1.1.1	No	Yes

※ Digital X-ray Image Storage – For Presentation is available only when Referral Viewing Function software (option) is installed.

Note : Tomosynthesis (including Reconstructed and S-View) images support the following SOP Class.

Computed Radiography Image Storage

Digital Mammography X-Ray Image Storage - For Presentation

Breast Tomosynthesis Image Storage

4.2.8.2 Association Policies

4.2.8.2.1 General

The DICOM standard application context name for DICOM 3.0 is always proposed:

TABLE 4.2- 73 DICOM APPLICATION CONTEXT FOR THE STORAGE-SCP AE

Application Context Name	1.2.840.10008.3.1.1.1
--------------------------	-----------------------

4.2.8.2.2 Number of Associations

AWS initiates one Association at a time for each destination to which a transfer request is being processed in the active job queue list. Only one job will be active at a time, the other remains pending until the active job is completed or failed.

TABLE 4.2- 74 NUMBER OF ASSOCIATIONS INITIATED FOR THE STORAGE-SCP AE

Maximum number of simultaneous Associations	1
---	---

4.2.8.2.3 Asynchronous Nature

AWS does not support asynchronous communication (multiple outstanding transactions over a single Association).

TABLE 4.2- 75 ASYNCHRONOUS NATURE FOR THE STORAGE-SCP AE

Maximum number of outstanding asynchronous transactions	1
---	---

4.2.8.2.4 Implementation Identifying Information

The implementation information for this Application Entity is:

TABLE 4.2- 76 DICOM IMPLEMENTATION CLASS AND VERSION FOR THE STORAGE-SCP AE

Implementation Class UID	1.2.392.200036.9125.5342.1
Implementation Version Name	A00

4.2.8.3 Association Initiation Policy

The Storage-SCP AE does not initiate associations.

4.2.8.4 Association Acceptance Policy

4.2.8.4.1 Activity - Receive Storage Request

When the Storage-SCP AE accepts an association, it will respond to storage requests.

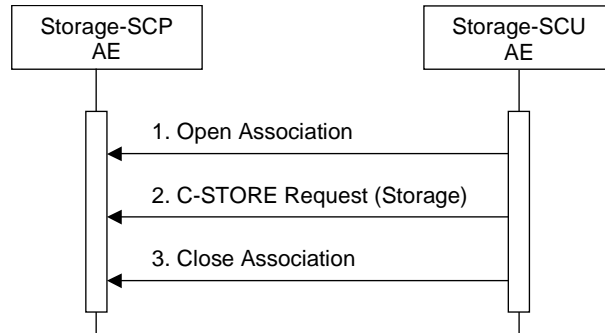

FIGURE 4.2- 11 SEQUENCING OF ACTIVITY – STORE IMAGES TO THE LOCAL FILE SYSTEM

A possible sequence of interactions between the Storage-SCP AE and a Storage-SCU AE is illustrated in Figure above:

1. The Storage-SCU AE opens an association with the Storage-SCP AE.
2. The Storage SCU AE sends images to the Storage SCP AE using a storage request (C-STORE) and the Storage SCP AE replies with a C-STORE response (status success).
3. The Storage-SCU AE closes the association with the Storage-SCP AE.

4.2.8.4.1.1 Accepted Presentation Contexts

The default Behavior of the Storage-SCP AE supports the Implicit VR Little Endian and Explicit VR Little Endian Transfer Syntaxes for all Associations.

Any of the Presentation Contexts shown in the following table are acceptable to the Storage-SCP AE for receiving images.

TABLE 4.2- 77 PROPOSED PRESENTATION CONTEXTS FOR ACTIVITY STORE IMAGES

Presentation Context Table					
Abstract Syntax		Transfer Syntax		Role	Ext. Neg.
Name	UID	Name List	UID List		
Computed Radiography Image Storage	1.2.840.10008.5.1.4.1.1.1	Implicit VR Little Endian	1.2.840.10008.1.2	SCP	None
		Explicit VR Little Endian	1.2.840.10008.1.2.1		
		JPEG Lossless Hierarchical First-Order Prediction	1.2.840.10008.1.2.4.70		
Digital Mammography X-	1.2.840.10008.5.1.4.1.1.1.2	Implicit VR Little Endian	1.2.840.10008.1.2	SCP	None
		Explicit VR Little Endian	1.2.840.10008.1.2.1		

Ray Image Storage – For Presentation		JPEG Lossless Hierarchical First-Order Prediction	1.2.840.10008.1.2.4.70		
Digital Mammography X-Ray Image Storage – For Processing	1.2.840.10008.5.1.4.1.1.1.2.1	Implicit VR Little Endian	1.2.840.10008.1.2	SCP	None
		Explicit VR Little Endian	1.2.840.10008.1.2.1		
		JPEG Lossless Hierarchical First-Order Prediction	1.2.840.10008.1.2.4.70		

NOTE: Multiple Transfer Syntax can be set in an Abstract Syntax, however only one setting that is set first is valid.

4.2.8.4.1.2 SOP Specific Conformance Image Storage SOP Classes

The associated Activity with the Storage service is the storage of medical image data received over the network on a designated hard disk. The Storage-SCP AE will return a failure status if it is unable to store the image on the local file system.

TABLE 4.2- 78 THE STORAGE-SCP AE C-STORE RESPONSE STATUS RETURN REASONS

Service Status	Further Meaning	Error Code	Behavior
Success	Success	0000	The SCP has successfully stored the SOP Instance. If all SOP Instances in a send job have status success then the job is marked as complete.
Refused	Out of Resources	A700	The Association is aborted using A-ABORT and the send job is marked as failed. The status meaning is logged and the job failure is reported to the user via the job control application. This is a transient failure.
Error	Data Set does not match SOP Class	A900	The Association is aborted using A-ABORT and the send job is marked as failed. The status meaning is logged and the job failure is reported to the user via the job control application.
*	*	Any other status code.	The Association is aborted using A-ABORT and the send job is marked as failed. The status code is logged and the job failure is reported to the user via the job control application.

4.3 NETWORK INTERFACES

4.3.1 Physical Network Interface

AWS supports a single network interface. One of the following physical network interfaces will be available depending on installed hardware options:

TABLE 4.3- 1 SUPPORTED PHYSICAL NETWORK INTERFACES

10 / 100 / 1000 Ethernet

4.3.2 Additional Protocols

The AWS Storage AE has no additional protocol.

4.3.3 IPv4 and IPv6 Support

The AWS only supports IPv4 connections.

4.4 CONFIGURATION

4.4.1 AE Title/Presentation Address Mapping

4.4.1.1 Local AE Titles

The Field Service Engineer can configure the AE Title via the Service/Installation Tool.

TABLE 4.4- 1 AE TITLE CONFIGURATION TABLE

Application Entity	Default AE Title	Default TCP/IP Port
Storage-SCU	FCR-CSL	104
Storage Commitment-SCU	FCR-CSL	104 (for receiving N-EVENT-REPORT)
MWM-SCU	FCR-CSL	104
MPPS-SCU	FCR-CSL	104
Print-SCU	FCR-CSL	104
Q/R-SCU	FCR-CSL	104
Storage-SCP	FCR-CSL	21760

※ When using Referral Viewing Function(Optional), Default AE Title and Default TCP/IP Port have to be set separately from those for FCR-CSL.

4.4.1.2 Remote AE Title/Presentation Address Mapping

4.4.1.2.1 Storage-SCU / Storage Commitment-SCU / Storage-SCP

The AE Title, host name, IP Address and port number of remote applications are configured using the AWS Service Tool. Associations from known AE Titles will be accepted and associations from unknown AE Titles will be rejected (an AE Title is known if it can be selected within the Service Tool). Multiple remote Storage-SCPs can be defined. Each Storage SCP can be configured to receive a storage commitment request.

4.4.1.2.2 MWM-SCU / MPPS-SCU

The AWS Service Tool must be used to set the AE Title, port-numbers, host-names and capabilities of the remote Modality Worklist SCP. Only a single remote Modality Worklist SCP can be defined.

The Service Tool must be used to set the AE Title, port-numbers, host-names and capabilities of the remote MPPS SCP. Only a single remote MPPS SCP can be defined.

4.4.1.2.3 Print-SCU

The AWS Service Tool must be used to set the AE Titles, port-numbers, host-names and capabilities for the remote Print-SCPs. Multiple remote Print-SCPs can be defined.

4.4.1.2.4 Q/R-SCU

The AWS Service Tool must be used to set the AE Titles, port-numbers, host-names and capabilities for the remote Q/R-SCPs. Multiple remote Q/R-SCPs can be defined.

4.4.2 Parameters

A large number of parameters related to acquisition and general operation can be configured using the Service Tool. The Table below only shows those configuration parameters relevant to DICOM communication.

TABLE 4.4- 2 CONFIGURATION PARAMETERS TABLE

Parameter	Configurable (Yes/No)	Default Value
Storage-SCU Parameters		
Supported Transfer Syntaxes (separately configurable for each remote AE). One of Implicit VR Little Endian, Explicit VR Little Endian, or JPEG Lossless	Yes	Implicit VR Little Endian
Storage-SCU time-out waiting for a response to a C-STORE-RQ	Yes	15 s
Storage-SCU Maximum Output Image Density One of 'ST' or 'HQ / SH'. Here, 'ST' indicates the low image density, 'HQ / SH' indicates the original image density or the high image density for mammography.	FDR-1000AWS / FDR-2000AWS: No CR-IR363AWS : Yes	HQ / SH
Storage-SCU Multi-Byte-Character (Remote Storage-SCP capable of using Multi-Byte-Character)	Yes	No
Maximum number of simultaneously accepted associations by the Storage-SCU AE	No	3
Storage Commitment-SCU Parameters		
Storage Commitment-SCU time-out waiting for a response to an N-ACTION-RQ	Yes	15 s
Storage-SCP Parameters		
Maximum number of simultaneously accepted associations by the Storage-SCP AE	No	1
MWM-SCU Parameters		
Supported Transfer Syntaxes	No	Implicit VR Little Endian
MWM-SCU time-out waiting for a response to a C-FIND-RQ	Yes	15 s
Maximum number of simultaneously accepted associations by the MWM-SCU AE	No	1
MPPS-SCU Parameters		
Supported Transfer Syntaxes	No	Implicit VR Little Endian
Maximum number of simultaneously accepted associations	No	1

Parameter	Configurable (Yes/No)	Default Value
by the MPPS-SCU AE		
Print-SCU Parameters		
Supported Transfer Syntaxes	No	Implicit VR Little Endian
Print-SCU time-out waiting for a response to each DIMSE	Yes	15 s
Print-SCU Multi-Byte-Character	Yes	No
Maximum number of simultaneously accepted associations by the Storage-SCU AE	No	1

5 MEDIA INTERCHANGE

5.1 IMPLEMENTATION MODEL

5.1.1 Application Data Flow

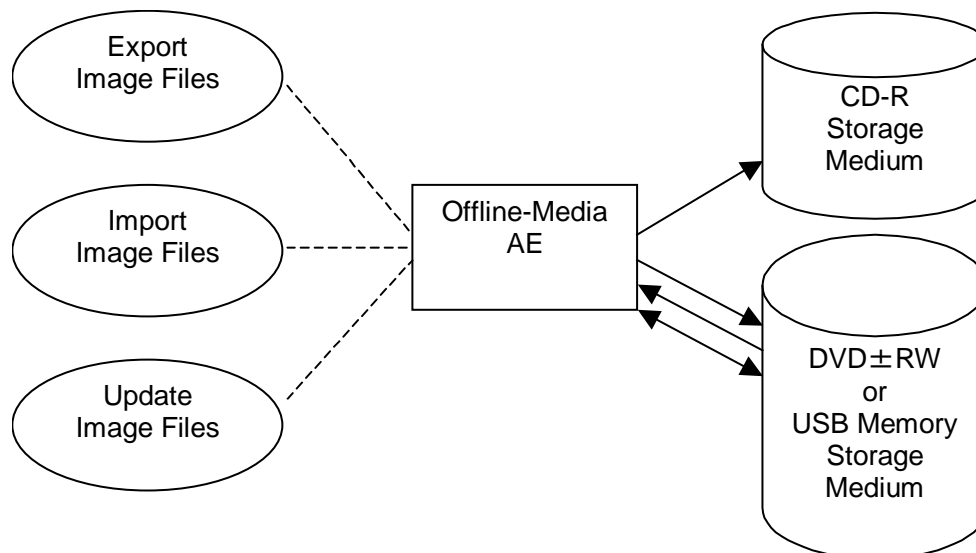

FIGURE 5.1- 1 APPLICATION DATA FLOW DIAGRAM FOR MEDIA STORAGE

- The Offline-Media AE exports images to a DVD±RW or USB Memory Storage medium. It is associated with the local real-world activity “Export Image Files”. “Export Image Files” is performed upon user request for selected studies.
- The Offline-Media AE imports images from a DVD±RW or USB Memory Storage medium. It is associated with the local real-world activity “Import Image Files”. “Import Image Files” is performed upon user request for selected studies.
- The Offline-Media AE updates images on a DVD±RW or USB Memory Storage medium. It is associated with the local real-world activity “Update Image Files”. “Update Image Files” is performed upon user request for selected studies.

5.1.2 Functional Definition of AEs

5.1.2.1 Functional Definition of Offline-Media Application Entity

Export Image Files:

The AWS builds DICOM Information Objects for storage and creates a DICOMDIR file that represents the contents of the DICOM Information Objects to be recorded. Then the AWS records DICOM Information Objects and the DICOMDIR file to the medium.

Import Image Files:

The AWS reads the DICOMDIR file and displays the ordered list of studies and images, identifying information. The AWS loads the selected studies/images from the medium and displays them on the screen.

Update Image Files:

The AWS reads a File-set of the medium and writes it to the local storage device. The AWS adds the studies/images to the File-Set, then writes it to the medium and modifies the DICOMDIR file.

5.1.3 Sequencing of Real-World Activities

5.1.3.1 Activity – Export Image Files

5.1.3.1.1 Activity – Export Image Files to DVD±RW or USB Memory

Operator requests to create new File-set(s) onto a Storage medium. The requests are placed in a queue and are executed in the background.

The operations for “Export Image Files to Storage medium” are described below:

1. Insert a medium and start mounting media manually if the setting is not automatic.
2. Select the studies on the study list of AWS to store to the medium.
3. Request to send to the medium.

5.1.3.2 Activity – Import Image Files

Operator requests to retrieve File-set(s) on the Storage medium.

The operations for “Import Image Files” are described below:

1. Insert a medium media that has File-set. And start mounting media manually if the setting is not automatic.
2. Select the studies from list on the medium.
3. Request to copy to the local storage device.

5.1.3.3 Activity – Update Image Files

Operator requests to add new objects to an already existing File-set on the Storage medium. The requests are placed in a queue and are executed in the background.

The operations for “Update Image Files” are described below:

1. Insert a medium that has File-set. And start mounting media manually if the setting is not automatic.
2. Select the studies on the study list of AWS to add to the medium.
3. Request to send to the medium.

5.1.4 File Meta Information Options

The implementation information written to the File Meta Header in each file is:

TABLE 5.1-1 DICOM IMPLEMENTATION CLASS AND VERSION FOR MEDIA STORAGE

File Meta Information Version	1
Implementation Class UID	1.2.392.200036.9125.5342.1
Implementation Version Name	A00

5.2 AE SPECIFICATIONS

5.2.1 Offline-Media Application Entity Specification

The Offline-Media Application Entity provides standard conformance to the Media Storage Service Class. The Application Profiles and roles are listed below:

TABLE 5.2-1 APPLICATION PROFILES, ACTIVITIES AND ROLES FOR OFFLINE-MEDIA

Application Profiles Supported	Real World Activity	Role	SC Option
AUG-GEN-DVD±RW	Export Image Files	FSC	Interchange
	Import Image Files	FSR	Interchange
	Update Image Files	FSU	Interchange
AUG-GEN-USB	Export Image Files	FSC	Interchange
	Import Image Files	FSR	Interchange
	Update Image Files	FSU	Interchange

5.2.1.1 File Meta Information for the Application Entity

The Source Application Entity Title included in the File Meta Header is configurable (see section 5.4).

5.2.1.2 Real-World Activities

5.2.1.2.1 Activity – Export Image Files

The Offline-Media Application Entity acts as an FSC when requested to export SOP Instances from the local database to a medium.

5.2.1.2.1.1 Media Storage Application Profiles

The Offline-Media Application Entity support the ‘AUG-GEN-DVD±RW’ or ‘AUG-GEN-USB’ Application Profile.

5.2.1.2.2 Activity – Import Image Files

The Offline-Media Application Entity acts as an FSR when requested to import SOP Instances from a medium to the local database.

5.2.1.2.2.1 Media Storage Application Profiles

The Offline-Media Application Entity support the ‘AUG-GEN-DVD±RW’ or ‘AUG-GEN-USB’ Application Profile.

5.2.1.2.3 Activity – Update Image Files

The Offline-Media Application Entity acts as an FSU when requested to update SOP Instances on a medium.

5.2.1.2.3.1 Media Storage Application Profiles

The Offline-Media Application Entity support the ‘AUG-GEN-DVD±RW’ or ‘AUG-GEN-USB’ Application Profile.

5.3 AUGMENTED AND PRIVATE APPLICATION PROFILES

5.3.1 Augmented Application Profiles

5.3.1.1 Augmented Application Profiles – AUG-GEN-DVD±RW and AUG-GEN-USB

Augmented Application Profiles support Standard Application Profiles, SC IOD and extended Transfer Syntax.

TABLE 5.3-1 AUGMENTED APPLICATION PROFILES

Application Profiles Supported	Standard Profiles Supported
AUG-GEN-DVD±RW	STD-GEN-DVD±RW
AUG-GEN-USB	STD-GEN-USB

5.3.1.1.1 SOP Class Augmentations

The aforementioned Application Profiles support following SOP Class UID and Transfer Syntax.

TABLE 5.3-2 SOP CLASS AUGMENTATIONS

Information Object Definition	SOP Class UID	Transfer Syntax	Transfer Syntax UID
Media Storage Directory Storage	1.2.840.10008.1.3.1.0	Explicit VR Little Endian	1.2.840.10008.1.2.1
		JPEG Lossless Hierarchical First-Order Prediction	1.2.840.10008.1.2.4.70
Computed Radiography Image Storage	1.2.840.10008.5.1.4.1.1.1	Implicit VR Little Endian	1.2.840.10008.1.2
		Explicit VR Little Endian	1.2.840.10008.1.2.1
		JPEG Lossless Hierarchical First-Order Prediction	1.2.840.10008.1.2.4.70
Digital Mammography Image Storage – For Presentation	1.2.840.10008.5.1.4.1.1.1.2	Implicit VR Little Endian (Only AUG-GEN-DVD ± RW, AUG-GEN-USB)	1.2.840.10008.1.2
		Explicit VR Little Endian	1.2.840.10008.1.2.1
		JPEG Lossless Hierarchical First-Order Prediction	1.2.840.10008.1.2.4.70
Breast Tomosynthesis Image Storage	1.2.840.10008.5.1.4.1.1.13.1.3	Implicit VR Little Endian (Only AUG-GEN-DVD ± RW, AUG-GEN-USB)	1.2.840.10008.1.2
		Explicit VR Little Endian	1.2.840.10008.1.2.1
		JPEG Lossless Hierarchical First-Order Prediction	1.2.840.10008.1.2.4.70

5.3.1.1.2 Directory Augmentations

Not applicable to this product.

5.3.1.1.3 Other Augmentations

Not applicable to this product.

5.3.2 Private Application Profiles

Not applicable to this product.

5.4 MEDIA CONFIGURATION

All local applications use the AE Titles configured via the Service/Installation Tool. The Application Entity Titles configurable for Media Services are listed in the Table below:

TABLE 5.4-1 AE TITLE CONFIGURATION TABLE

Application Entity	Default AE Title
Offline-Media	No Default

6 SUPPORT OF CHARACTER SETS

ISO-IR 100 (Latin Alphabet #1)

ISO-IR 101 (Latin Alphabet #2)

ISO-IR 13/14 (Japanese Katakana: JIS X 0201)

ISO-IR 87 (Japanese Kanji: JIS X 0208)

ISO-IR 149 (Korean: EUC-KR)

ISO-IR 192 (Unicode: UTF-8)

GB18030

7 SECURITY

AWS does not support any specific security measures.

It is assumed that AWS is used within a secured environment. It is assumed that a secured environment includes at a minimum:

- a. Firewall or router protections to ensure that only approved external hosts have network access to AWS.
- b. Firewall or router protections to ensure that AWS only has network access to approved external hosts and services.
- c. Any communication with external hosts and services outside the locally secured environment use appropriate secure network channels (e.g. such as a Virtual Private Network (VPN))

Other network security procedures such as automated intrusion detection may be appropriate in some environments. Additional security features may be established by the local security policy and are beyond the scope of this conformance statement.

8 ANNEXES

8.1 IOD CONTENTS

8.1.1 Created SOP Instances

Table 8.1-1 specifies the attributes of a CR Image transmitted by the Storage-SCU AE.

Table 8.1-2 specifies the attributes of a MG Image transmitted by the Storage-SCU AE.

Table 8.1-3-1 specifies the attributes of a BT Image transmitted by the Storage-SCU AE.

The following tables use a number of abbreviations. The abbreviations used in the “Presence of ...” column are:

VNAP	Value Not Always Present (attribute sent zero length if no value is present)
ANAP	Attribute Not Always Present
ALWAYS	Always Present
EMPTY	Attribute is sent without a value (attribute always sent zero length)

The abbreviations used in the “Source” column:

MWL	the attribute value source Modality Worklist
USER	the attribute value source is from User input
AUTO	the attribute value is generated automatically
CONFIG	the attribute value source is a configurable parameter
OTHER	the attribute value source is from other modality

NOTE: All dates and times are encoded in the local configured calendar and time. Date, Time and Time zone are configured using the Service/Installation Tool.

The following tables describe just the attributes which AWS generates. The attributes which other modalities or the equipments generated is sent, if they exist, that way.

8.1.1.1 Computed Radiography Image IOD

TABLE 8.1- 1 IOD OF CREATED CR IMAGE STORAGE SOP INSTANCES

IE	Module	Usage	Reference
Patient	Patient	M	Table 8.1-6
	Clinical Trial Subject	U	Not Supported
Study	General Study	M	Table 8.1-7
	Patient Study	U	Table 8.1-8
	Clinical Trial Study	U	Not Supported
Series	General Series	M	Table 8.1-9
	CR Series	M	Table 8.1-10
	Clinical Trial Series	U	Not Supported
Equipment	General Equipment	M	Table 8.1-15
Image	General Image	M	Table 8.1-17
	Image Pixel	M	Table 8.1-19
	Contrast/bolus	C - Required if contrast media was used in this image	Table 8.1-20
	Device	U	Not Supported
	CR Image	M	Table 8.1-21
	Overlay Plane	U	Not Supported
	Modality LUT	U	Table 8.1-30
	VOI LUT	U	Table 8.1-31
	SOP Common	M	Table 8.1-37
	Extended	DX Positioning	-
X-Ray Acquisition Dose		-	Table 8.1-27
X-Ray Generation		-	Table 8.1-28
X-Ray Grid		-	Table 8.1-29

NOTE: In Extended module, type of all attributes is 3.

The IOD includes Private attributes and standard extended attributes documented in section 8.2. See 8.2 and 8.5.

8.1.1.2 Digital Mammography X-Ray Image Radiography Image IOD

TABLE 8.1- 2 IOD OF CREATED MG IMAGE STORAGE SOP INSTANCES

IE	Module	Usage	Reference
Patient	Patient	M	Table 8.1-6
	Specimen Identification	U	Not Supported
	Clinical Trial Subject	U	Not Supported
Study	General Study	M	Table 8.1-7
	Patient Study	U	Table 8.1-8
	Clinical Trial Study	U	Not Supported
Series	General Series	M	Table 8.1-9
	Clinical Trial Series	U	Not Supported
	DX Series	M	Table 8.1-11
	Mammography Series	M	Table 8.1-12
Equipment	General Equipment	M	Table 8.1-15
Image	General Image	M	Table 8.1-17
	Image Pixel	M	Table 8.1-19
	Contrast/bolus	U	Table 8.1-20
	Display Shutter	U	Not Supported
	Device	U	Not Supported
	Intervention	U	Not Supported
	DX Anatomy Imaged	M	Included in the Mammography Image Module.
	DX Image	M	Table 8.1-22
	DX Detector	M	Table 8.1-24
	X-Ray Collimator	U	Not Supported
	DX Positioning	U	Table 8.1-25
	X-Ray Tomography Acquisition	U	Table 8.1-26
	X-Ray Acquisition Dose	U	Table 8.1-27
	X-Ray Generation	U	Table 8.1-28
	X-Ray Filtration	U	Not Supported
	X-Ray Grid	U	Table 8.1-29
	Mammography Image	M	Table 8.1-23
	Overlay Plane	C - Required if graphic annotation is present	Not Supported

IE	Module	Usage	Reference
	VOI LUT	C - Required if Presentation Intent Type (0008,0068) is FOR PRESENTATION. Shall not be present otherwise.	Table 8.1-31
	Image Histogram	U	Not Supported
	Acquisition Context	M	Table 8.1-32
	SOP Common	M	Table 8.1-37
Frame of Reference	Frame of Reference	U	Table 8.1-14
Extended	Image Plane	U	Table 8.1-18

NOTE: The IOD includes Private attributes and standard extended attributes documented in section 8.2. See 8.2 and 8.5.

8.1.1.3 Breast Tomosynthesis Image Storage IOD

8.1.1.3.1 Breast Tomosynthesis Image IOD Module Table

TABLE 8.1- 3-1 IOD OF BREAST TOMOSYNTHESIS IMAGE STORAGE SOP INSTANCES

IE	Module	Usage	Reference
Patient	Patient	M	Table 8.1-6
	Clinical Trial Subject	U	Not Supported
Study	General Study	M	Table 8.1-7
	Patient Study	U	Table 8.1-8
	Clinical Trial Study	U	Not Supported
Series	General Series	M	Table 8.1-9
	Clinical Trial Series	U	Not Supported
	Enhanced Mammography Series	M	Table 8.1-13
Frame of Reference	Frame of Reference	M	Table 8.1-14
	Synchronization	C-Required if time synchronization was applied.	Not Supported
Equipment	General Equipment	M	Table 8.1-15
	Enhanced General Equipment	M	Table 8.1-16
Image	Image Pixel	M	Table 8.1-19
	Enhanced Contrast/Bolus	C-Required if contrast media was applied.	Not Supported
	Device	U	Not Supported
	Intervention	U	Not Supported
	Acquisition Context	M	Table 8.1-32
	Multi-frame Functional Groups	M	Table 8.1-33
	Multi-frame Dimension Module	U	Not Supported
	Image – Equipment Coordinate Relationship	U	Not Supported
	Specimen	U	Not Supported
	X-Ray 3D Image	M	Table 8.1-35
	Breast Tomosynthesis Contributing Sources	U	Table 8.1-36
	Breast Tomosynthesis Acquisition	U	Table 8.1-37
	X-Ray 3D Reconstruction	U	Table 8.1-38
	Breast View	M	Table 8.1-39
	SOP Common	M	Table 8.1-40
	Frame Extraction	C-Required if the SOP Instance was created in response to a Frame-Level retrieve request	Not Supported
Extended	X-Ray Acquisition Dose	-	Table 8.1-27
	X-Ray Tomography Acquisition Dose	-	Table 8.1-26

IE	Module	Usage	Reference
	X-Ray Generation	-	Table 8.1-28
	DX Positioning	-	Table 8.1-25
	X-Ray Grid	-	Table 8.1-29

NOTE: The IOD includes Private attributes and standard extended attributes documented in section 8.2. See 8.2 and 8.5.

8.1.1.3.1.1 Breast Tomosynthesis Image IOD Content Constraints

8.1.1.3.1.1.1 Restrictions for Standard Extended SOP Classes

The Overlay Plane Module, Modality LUT Module, VOI LUT Module and Softcopy Presentation LUT Module shall not be used in a Standard Extended SOP Class of the Breast Tomosynthesis Image.

NOTE: The VOI LUT function is provided by a Frame VOI LUT Functional Group.

8.1.1.3.2 Breast Tomosynthesis Image Functional Group Macros

Table 8.1.3-2 specifies the use of the Functional Group macros used in the Multi-frame Functional Groups Module for the Breast Tomosynthesis Image IOD.

TABLE 8.1- 3-2 IOD OF BREAST TOMOSYNTHESIS IMAGE STORAGE SOP INSTANCES

Functional Group Macro	Usage	Reference
Pixel Measures	M	Table 8.1-34(Pixel Measures)
Frame Content	M-May not be used as a Shared Functional Group.	Table 8.1-34(Frame Content)
Plane Position (Patient)	M	Table 8.1-34(Plane Position (Patient))
Plane Orientation(Patient)	M	Table 8.1-34(Plane Orientation (Patient))
Referenced Image	U	Not Supported
Derivation Image	C-Required if the Image Type(0008,0008) Value 1 equals DERIVED.	Table 8.1-34(Derivation Image)
Frame Anatomy	M	Table 8.1-34(Frame Anatomy)
Identity Pixel Value Transformation	M	Table 8.1-34(Identity Pixel Value Transformation)
Frame VOI LUT With LUT	M	Table 8.1-34(Frame VOI LUT With LUT)
Real World Value Mapping	U	Not Supported
Contrast/Bolus Usage	C-Required if the Enhanced	Not Supported

Functional Group Macro	Usage	Reference
	Contrast/Bolus Module is present.	
X-Ray 3D Frame Type	M-May not be used as a Shared Functional Group.	Table 8.1-34(X-Ray 3D Frame Type)

8.1.1.3.2.1 Breast Tomosynthesis Image Functional Group Macros Content Constraints

8.1.1.3.1.1.1 Frame Anatomy Functional Group Macro

The Defined Context ID for the Anatomic Region Sequence(0008,2218) shall be CID 4013.

8.1.1.3.3 Output Method of Breast Tomosynthesis Image

Brest Tomosynthesis Image Storage supports two methods of the multi-frame image outputting in Figure below. The first method is that the multi-frame image is outputted one by one. Another method is that connected data of the multi-frame image is outputted. When connected data is output and the capacity of dicom file is more than config value, dicom file of the capacity in the range is divided and is output. The Field Service Engineer can configure it via the Service/Installation Tool.

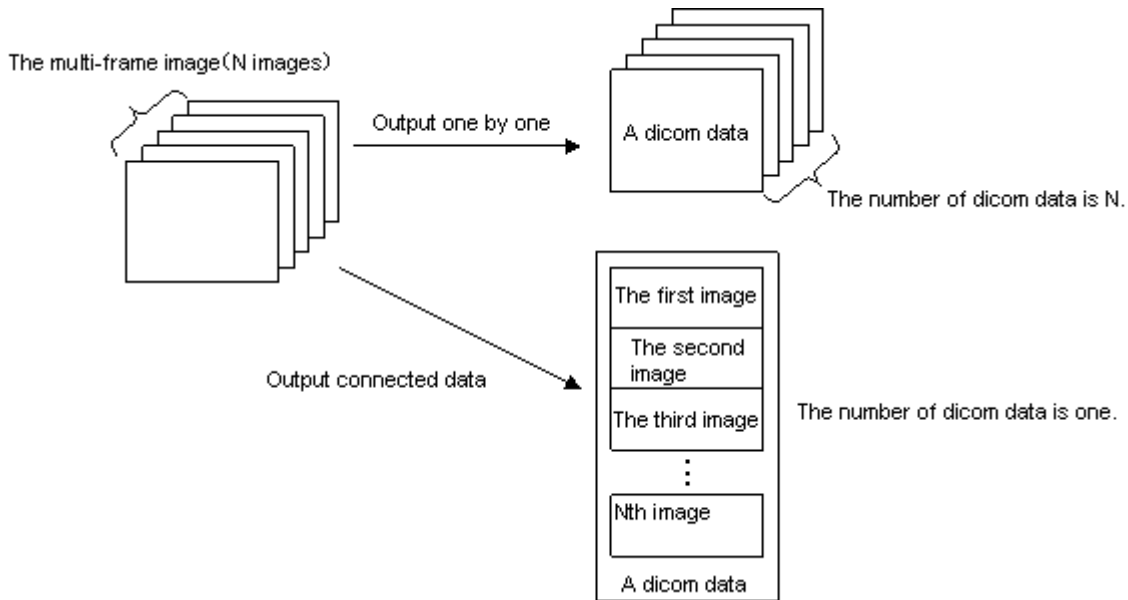

FIGURE 8.1- 3 OUTPUT METHOD OF BREAST TOMOSYNTHESIS IMAGE STORAGE

8.1.1.4 Key Object Selection IOD

TABLE 8.1- 4 IOD OF KEY OBJECT SELECTION DOCUMENT SOP INSTANCES

IE	Module	Usage	Reference
Patient	Patient	M	Table 8.1-6
	Clinical Trial Subject	U	Not Supported
Study	General Study	M	Table 8.1-7
	Patient Study	U	Not Supported
	Clinical Trial Study	U	Not Supported
Series	Key Object Document Series	M	Table 8.1-42
	Clinical Trial Series	U	Not Supported
Equipment	General Equipment	M	Table 8.1-15
Document	Key Object Document	M	Table 8.1-41
	SR Document Content	M	Table 8.1-43
	SOP Common	M	Table 8.1-40

NOTE: The IOD includes Private attributes and standard extended attributes documented in section 8.2. See 8.2 and 8.5.

8.1.1.5 X-Ray Radiation Dose SR IOD

TABLE 8.1- 5 IOD OF CREATED X-RAY RADIATION DOSE SR SOP INSTANCES

IE	Module	Usage	Reference
Patient	Patient	M	Table 8.1-6
	Specimen Identification	U	Not Supported
	Clinical Trial Subject	U	Not Supported
Study	General Study	M	Table 8.1-7
	Patient Study	U	Not Supported
	Clinical Trial Study	U	Not Supported
Series	SR Document Series	M	Table 8.1-50
	Clinical Trial Series	U	Not Supported
Frame of Reference	Synchronization	U	Not Supported
Equipment	General Equipment	M	Table 8.1-15
	Enhanced General Equipment	M	Table 8.1-16
Document	SR Document General	M	Table 8.1-51
	SR Document Content	M	Table 8.1-43
	SOP Common	U	Table 8.1-40

NOTE: The IOD includes Private attributes and standard extended attributes documented in Section 8.2. See 8.2 and 8.5.

8.1.1.6 Patient Module

TABLE 8.1- 6 PATIENT MODULE OF CREATED SOP INSTANCES

Attribute Name	Tag	Type	DICOM Attribute Description	Presence of Value	Source
Patient's Name	(0010,0010)	2	Patient's full name.	VNAP	USER /MWL
Patient ID	(0010,0020)	2	Primary hospital identification number or code for the patient.	VNAP	USER /MWL
Patient's Birth Date	(0010,0030)	2	Birth date of the patient.	VNAP	USER /MWL
Patient's Sex	(0010,0040)	2	Sex of the named patient. Enumerated Values: M = male F = female O = other	VNAP	USER /MWL
Other Patient IDs	(0010,1000)	3	Other identification numbers or codes used to identify the patient.	ANAP	MWL
Ethnic Group	(0010,2160)	3	Ethnic group or race of patient.	ANAP	MWL
Patient Comments	(0010,4000)	3	User-defined comments about the patient.	ANAP	USER /MWL

8.1.1.7 General Study Module

TABLE 8.1- 7 GENERAL STUDY MODULE OF CREATED SOP INSTANCES

Attribute Name	Tag	Type	DICOM Attribute Description	Presence of Value	Source
Study Instance UID	(0020,000D)	1	Unique identifier for the Study.	ALWAYS	MWL /AUTO /CONFIG
Study Date	(0008,0020)	2	Date the Study started.	ALWAYS	AUTO
Study Time	(0008,0030)	2	Time the Study started.	ALWAYS	AUTO
Referring Physician's Name	(0008,0090)	2	Name of the patient's referring physician	VNAP	MWL
Study ID	(0020,0010)	2	User or equipment generated Study identifier.	VNAP	MWL
Accession Number	(0008,0050)	2	A RIS generated number that identifies the order for the Study.	VNAP	USER /MWL
Study Description	(0008,1030)	3	Institution-generated description or classification of the Study (component) performed.	ANAP	MWL
Physician(s) of Record	(0008,1048)	3	Names of the physician(s) who are responsible for overall patient care at time of Study	ANAP	OTHER
Reason For Performed Procedure Code Sequence	(0040,1012)	3	Coded reason(s) for performing this procedure. One or more Items may be included in this Sequence. Note: May differ from the values in Reason for the Requested Procedure (0040,100A) in Request Attribute Sequence (0040,0275), for example if what was performed differs from what was requested.	ANAP	MWL

8.1.1.8 Patient Study Module

TABLE 8.1- 8 PATIENT STUDY MODULE OF CREATED SOP INSTANCES

Attribute Name	Tag	Type	DICOM Attribute Description	Presence of Value	Source
Patient's Age	(0010,1010)	3	Age of Patient.	ANAP	USER
Additional Patient's History	(0010,21B0)	3	Additional information about the Patient's medical history.	ANAP	MWL

8.1.1.9 General Series Module

TABLE 8.1- 9 GENERAL SERIES MODULE OF CREATED SOP INSTANCES

Attribute Name	Tag	Type	DICOM Attribute Description	Presence of Value	Source
Modality	(0008,0060)	1	Type of equipment that originally acquired the data used to create the images in this Series.	ALWAYS Value is "CR" or "MG"	AUTO
Operators' Name	(0008,1070)	3	Name(s) of the operator(s) supporting the Series.	ANAP	CONFIG /USER
Series Instance UID	(0020,000E)	1	Unique identifier of the Series.	ALWAYS	AUTO
Series Number	(0020,0011)	2	A number that identifies this Series.	VNAP	AUTO
Laterality	(0020,0060)	2C	Laterality of (paired) body part examined. Required if the body part examined is a paired structure and Image Laterality (0020,0062) or Frame Laterality (0020,9072) are not sent. Enumerated Values: R = right L = left	VNAP	AUTO
Series Date	(0008,0021)	3	Date the Series started.	ANAP	AUTO
Series Time	(0008,0031)	3	Time the Series started.	ANAP	AUTO
Series Description	(0008,103E)	3	User provided description of the Series	ANAP	OTHER
Protocol Name	(0018,1030)	3	User-defined description of the conditions under which the Series was performed.	ANAP	OTHER
Body Part Examined	(0018,0015)	3	Text description of the part of the body examined. Defined Terms: SKULL, CSPINE, TSPINE, LSPINE, SSPINE, COCCYX, CHEST, CLAVICLE, BREAST, ABDOMEN, PELVIS, HIP, SHOULDER, ELBOW, KNEE, ANKLE, HAND, FOOT, EXTREMITY, HEAD, HEART, NECK, LEG, ARM, JAW	ALWAYS Values shown below are used. Body part definitions not existing in the DICOM definitions will be added. HEAD, NECK, CHEST, BREAST, ABDOMEN, PELVIS, UP_EXM, LOW_EXM, TEST	USER

Attribute Name	Tag	Type	DICOM Attribute Description	Presence of Value	Source
Performed Procedure Step ID	(0040,0253)	3	User or equipment generated identifier of that part of a Procedure that has been carried out within this step.	ANAP	AUTO
Performed Procedure Step Start Date	(0040,0244)	3	Date on which the Performed Procedure Step started.	ANAP	AUTO
Performed Procedure Step Start Time	(0040,0245)	3	Time on which the Performed Procedure Step started.	ANAP	AUTO
Performed Procedure Step Description	(0040,0254)	3	Institution-generated description or classification of the Procedure Step that was performed.	ANAP	AUTO
Performed Protocol Code Sequence	(0040,0260)	3	Sequence describing the Protocol performed for this Procedure Step. One or more Items may be included in this Sequence.	ANAP	AUTO
>Code Value	(0008,0100)	1C	Required if a sequence item is present.	ANAP	AUTO
>Coding Scheme Designator	(0008,0102)	1C	Required if a sequence item is present.	ANAP	AUTO
>Coding Scheme Version	(0008,0103)	1C	Required if a sequence item is present. Required if the value of Coding Scheme Designator (0008,0102) is not sufficient to identify the Code Value (0008,0100) unambiguously.	ANAP	AUTO
>Code Meaning	(0008,0104)	1C	Required if a sequence item is present.	ANAP	AUTO
Request Attributes Sequence	(0040,0275)	3	Sequence that contains attributes from the Imaging Service Request. The sequence may have one or more Items.	ANAP	AUTO
>Requested Procedure ID	(0040,1001)	1C	Identifier which identifies the Requested Procedure in the Imaging Service Request.	ANAP	MWL
>Scheduled Procedure Step ID	(0040,0009)	1C	Identifier which identifies the Scheduled Procedure Step.	ANAP	MWL

Attribute Name	Tag	Type	DICOM Attribute Description	Presence of Value	Source
>Scheduled Procedure Step Description	(0040,0007)	3	Institution-generated description or classification of the Scheduled Procedure Step to be performed.	ANAP	MWL
>Scheduled Protocol Code Sequence	(0040,0008)	3	Sequence describing the Scheduled Protocol following a specific coding scheme. This sequence contains one or more items.	ANAP	MWL
>>Code Value	(0008,0100)	1C	Required if a sequence item is present.	ANAP	MWL
>>Coding Scheme Designator	(0008,0102)	1C	Required if a sequence item is present.	ANAP	MWL
>>Coding Scheme Version	(0008,0103)	1C	Required if a sequence item is present. Required if the value of Coding Scheme Designator (0008,0102) is not sufficient to identify the Code Value (0008,0100) unambiguously.	ANAP	MWL
>>Code Meaning	(0008,0104)	1C	Required if a sequence item is present.	ANAP	MWL
>Referenced Study Sequence	(0008,1110)	3	Uniquely identifies the Study SOP Instances associated with this SOP Instance. One or more items may be included.	ANAP	MWL
>>Referenced SOP Class UID	(0008,1150)	1	Uniquely identifies the referenced SOP Class.	ANAP	MWL
>>Referenced SOP Instance UID	(0008,1155)	1	Uniquely identifies the referenced SOP Instance.	ANAP	MWL
>Reason for Requested Procedure Code Sequence	(0040,100A)	3	Coded Reason for requesting this procedure. One or more sequence items may be present.	ANAP	MWL

8.1.1.10 CR Series Module

TABLE 8.1- 10 CR SERIES MODULE OF CREATED CR IMAGE STORAGE SOP INSTANCES

Attribute Name	Tag	Type	DICOM Attribute Description	Presence of Value	Source
Body Part Examined	(0018,0015)	2	Text description of the part of the body examined. Defined Terms: SKULL, CSPINE, TSPINE, LSPINE, SSPINE, COCCYX, CHEST, CLAVICLE, BREAST, ABDOMEN, PELVIS, HIP, SHOULDER, ELBOW, KNEE, ANKLE, HAND, FOOT, EXTREMITY, HEAD, HEART, NECK, LEG, ARM, JAW	ALWAYS Values shown below are used. Body part definitions not existing in the DICOM definitions will be added. HEAD, NECK, CHEST, BREAST, ABDOMEN, PELVIS, UP_EXM, LOW_EXM, TEST	USER
View Position	(0018,5101)	2	Radiographic view associated with Patient Position (0018,5100). Defined Terms: AP = Anterior/Posterior PA = Posterior/Anterior LL = Left Lateral RL = Right Lateral RLD = Right Lateral Decubitus LLD = Left Lateral Decubitus RLO = Right Lateral Oblique LLO = Left Lateral Oblique	VNAP	AUTO

8.1.1.11 DX Series Module

TABLE 8.1- 11 DX SERIES MODULE OF CREATED MG IMAGE STORAGE SOP INSTANCES

Attribute Name	Tag	Type	DICOM Attribute Description	Presence of Value	Source
Modality	(0008,0060)	1	Type of equipment that originally acquired the data used to create the images in this Series. Enumerated Values: DX,PX,IO,MG	ALWAYS See 8.1.1.12	AUTO
Referenced Performed Procedure Step Sequence	(0008,1111)	1C	Uniquely identifies the Performed Procedure Step SOP Instance to which the Series is related (e.g. a Modality or General-Purpose Performed Procedure Step SOP Instance). The Sequence shall have one Item. Required if the Modality Performed Procedure Step SOP Class, General Purpose Performed Procedure Step SOP Class is supported.	ANAP	AUTO
>Referenced SOP Class UID	(0008,1150)	1C	Uniquely identifies the referenced SOP Class. Required if Referenced Performed Procedure Step Sequence (0008,1111) is sent.	ANAP	AUTO
>Referenced SOP Instance UID	(0008,1155)	1C	Uniquely identifies the referenced SOP Instance. Required if Referenced Performed Procedure Step Sequence (0008,1111) is sent.	ANAP	AUTO
Presentation Intent Type	(0008,0068)	1	Identifies the intent of the images that are contained within this Series. Enumerated Values: FOR PRESENTATION FOR PROCESSING	ALWAYS In case S-View, the value is "FOR PRESENTATION" only.	CONFIG

8.1.1.12 Mammography Series Module

TABLE 8.1- 12 MAMMOGRAPHY SERIES MODULE OF CREATED MG IMAGE STORAGE SOP INSTANCES

Attribute Name	Tag	Type	DICOM Attribute Description	Presence of Value	Source
Modality	(0008,0060)	1	Type of equipment that originally acquired the data used to create the images in this Series. Enumerated Values: MG	ALWAYS Value is "MG"	AUTO
Request Attributes Sequence	(0040,0275)	3	Sequence that contains attributes from the Imaging Service Request. The sequence may have one or more Items.	ANAP	MWL
>Reason for Requested Procedure Code Sequence	(0040,100A)	3	Coded Reason for requesting this procedure. One or more sequence items may be present.	ANAP	MWL

8.1.1.13 Enhanced Mammography Series Module

TABLE 8.1- 13 ENHANCED MAMMOGRAPHY SERIES MODULE OF CREATED BREAST TOMOSYNTHESIS IMAGE STORAGE SOP INSTANCES

Attribute Name	Tag	Type	DICOM Attribute Description	Presence of Value	Source
Modality	(0008,0060)	1	Type of equipment that originally acquired the data used to create the images in this Series. Enumerated Values: MG	ALWAYS Value is "MG"	AUTO
Referenced Performed Procedure Step Sequence	(0008,1111)	1C	Uniquely identifies the Performed Procedure Step SOP Instance to which the Series is related (e.g. a Modality or General-Purpose Performed Procedure Step SOP Instance). Only a single Item shall be included in this sequence. Required if the Modality Performed Procedure Step SOP Class or General Purpose Performed Procedure Step SOP Class is supported.	ANAP	AUTO
Request Attributes Sequence	(0040,0275)	3	Sequence that contains attributes from the Imaging Service Request. One or more Items are permitted in this sequence.	ANAP	AUTO

8.1.1.14 Frame of Reference Module

TABLE 8.1- 14 FRAME OF REFERENCE MODULE OF CREATED BREAST TOMOSYNTHESIS IMAGE STORAGE SOP INSTANCES

Attribute Name	Tag	Type	DICOM Attribute Description	Presence of Value	Source
Frame of Reference UID	(0020,0052)	1	Uniquely identifies the frame of reference for a Series.	ALWAYS UID of S-View is same as reconstructed image. In the case of a set menu, UID of 2D image is also same as the reconstructed image.	AUTO
Position Reference Indicator	(0020,1040)	2	Part of the imaging target used as a reference.	VNAP	AUTO

8.1.1.15 General Equipment Module

TABLE 8.1- 15 GENERAL EQUIPMENT MODULE OF CREATED SOP INSTANCES

Attribute Name	Tag	Type	DICOM Attribute Description	Presence of Value	Source
Manufacturer	(0008,0070)	2	Manufacturer of the equipment that produced the composite instances.	ALWAYS Value is "FUJIFILM Corporation"	AUTO
Institution Name	(0008,0080)	3	Institution where the equipment that produced the composite instances is located.	ANAP	CONFIG
Institution Address	(0008,0081)	3	Mailing address of the institution where the equipment that produced the composite instances is located.	ANAP	CONFIG
Station Name	(0008,1010)	3	User defined name identifying the machine that produced the composite instances.	ALWAYS	CONFIG
Institutional Department Name	(0008,1040)	3	Department in the institution where the equipment that produced the composite instances is located.	ANAP	OTHER
Manufacturer's Model Name	(0008,1090)	3	Manufacturer's model name of the equipment that produced the composite instances.	ANAP	AUTO
Device Serial Number	(0018,1000)	3	Manufacturer's serial number of the equipment that produced the composite instances.	ANAP	CONFIG
Software Versions	(0018,1020)	3	Manufacturer's designation of software version of the equipment that produced the composite instances.	ANAP Value is "FDR-1000AWS Mainsoft Vx.x", "FDR-2000AWS Mainsoft Vx.x", "CR-IR363AWS Mainsoft Vx.x"	AUTO
Gantry ID	(0018,1008)	3	Identifier of the gantry or positioner.	ANAP	CONFIG

Attribute Name	Tag	Type	DICOM Attribute Description	Presence of Value	Source
Pixel Padding Value	(0028,0120)	1C	Single pixel value or one limit (inclusive) of a range of pixel values used in an image to pad to rectangular format or to signal background that may be suppressed. See DICOM PS3.3 C.7.5.1.1.2 for further explanation. Required if Pixel Padding Range Limit (0028,0121) is present. May be present otherwise.	ANAP	AUTO /USER

8.1.1.16 Enhanced General Equipment Module

TABLE 8.1- 16 ENHANCED GENERAL EQUIPMENT MODULE OF CREATED SOP INSTANCES

Attribute Name	Tag	Type	DICOM Attribute Description	Presence of Value	Source
Manufacturer	(0008,0070)	1	Manufacturer of the equipment that produced the composite instances.	ALWAYS	AUTO
Device Serial Number	(0018,1000)	1	Manufacturer's serial number of the equipment that produced the composite instances.	ALWAYS	AUTO
Software Versions	(0018,1020)	1	Manufacturer's designation of software version of the equipment that produced the composite instances.	ALWAYS	AUTO

8.1.1.17 General Image Module

TABLE 8.1- 17 GENERAL IMAGE MODULE OF CREATED SOP INSTANCES

Attribute Name	Tag	Type	DICOM Attribute Description	Presence of Value	Source
Instance Number	(0020,0013)	2	A number that identifies this image.	ALWAYS	AUTO
Patient Orientation	(0020,0020)	2C	Patient direction of the rows and columns of the image. Required if image does not require Image Orientation (Patient) (0020,0037) and Image Position (Patient) (0020,0032).	VNAP	CONFIG /USER
Content Date	(0008,0023)	2C	The date the image pixel data creation started. Required if image is part of a series in which the images are temporally related.	ALWAYS	AUTO
Content Time	(0008,0033)	2C	The time the image pixel data creation started. Required if image is part of a series in which the images are temporally related.	ALWAYS	AUTO
Image Type	(0008,0008)	3	Image identification characteristics.	ALWAYS See Note 1 below.	AUTO
Acquisition Number	(0020,0012)	3	A number identifying the single continuous gathering of data over a period of time that resulted in this image.	ANAP	AUTO
Acquisition Date	(0008,0022)	3	The date the acquisition of data that resulted in this image started	ALWAYS In case Tomosynthesis (including Reconstructed and S-View), the value is same as the first projection image.	AUTO
Acquisition Time	(0008,0032)	3	The time the acquisition of data that resulted in this image started	ALWAYS In case Tomosynthesis (including Reconstructed and S-View), the value is same as the first projection image.	AUTO
Derivation Description	(0008,2111)	3	A text description of how this image was derived.	ANAP	AUTO

Attribute Name	Tag	Type	DICOM Attribute Description	Presence of Value	Source
Source Image Sequence	(0008,2112)	3	A Sequence that identifies the set of Image SOP Class/Instance pairs of the Images that were used to derive this Image. Zero or more Items may be included in this Sequence.	ANAP	AUTO
>Referenced SOP Class UID	(0008,1150)	1	Uniquely identifies the referenced SOP Class.	ANAP	AUTO
>Referenced SOP Instance UID	(0008,1155)	1	Uniquely identifies the referenced SOP Instance.	ANAP	AUTO
>Spatial Locations Preserved	(0028,135A)	3	The extent to which the spatial locations of all pixels are preserved during the processing of the source image that resulted in the current image Enumerated Values: YES NO REORIENTED_ONLY - A projection radiograph that has been flipped, and/or rotated by a multiple of 90 degrees	ANAP Value is "YES" See Note 3 below.	AUTO
Image Comments	(0020,4000)	3	User-defined comments about the image.	ANAP	USER
Lossy Image Compression	(0028,2110)	3	Specifies whether an Image has undergone lossy compression. Enumerated Values: 00 = Image has NOT been subjected to lossy compression. 01 = Image has been subjected to lossy compression. See PS3.3 C.7.6.1.1.5	ALWAYS Value is "00"	AUTO
Pixel Spacing	(0028,0030)	3	Extended Attribute. Physical distance, within the patient, between the centers of each pixel. Expressed as a numerical set: space between adjoining rows (delimiter), space between adjoining columns. Unit: mm.	ALWAYS See Note 2 below.	AUTO

Note 1:

The Image Type consists of the following elements as per DICOM definitions.

Value 1: Pixel data Characteristics

Value 2: Patient Examination Characteristics

Value 3: Modality Specific Characteristics

Value 4 or after: Other Value “n” (“n” represents a numeric value.)

On the FCR system, the above values should be interpreted as described below. Note that each of the elements may be omitted (only delimiters exist). When a portion after a certain element is fully omitted, even delimiters do not exist.

Because Value 1 and Value 2 have DICOM-defined meanings, they comply with the DICOM definitions. If omitted, they will be considered to be “ORIGINAL” or “PRIMARY”.

Value 3 determines image data types such as pre-normalized image, normalized image or processed image. If omitted, it will be considered to be “NORMALIZED”.

Value 4 (Other Value 1) represents processing purpose type of an image. When omitted, it will be considered to be “RT”.

Value 5 (Other Value 2) determines a types of change processing performed on an original image. Value 5 will not be determined if no changes have been made.

Value 6 (Other Value 3) determines a date of the change made on an image with Value 5 (Other Value 2) above. Value 6 will not be determined if no changes have been made.

Value 7 (Other Value 4) determines a type of special processing performed on an image, which will not be determined if no special image processing has been performed.

Value 8 (Other Value 5) determines a date of the special image processing performed with Value 7 (Other Value 4) above. Value 8 will not be determined if no special image processing has been performed.

Value 9 (Other Value 6) determines the distance (nm) between the centers of each pixel when an IP is read.

Each of the values mentioned above will represent the following specific meaning.

Value 1: (as per DICOM definitions)

(In cases of Computed Radiography Image Storage and FUJI Private Computed Radiography Image Storage)

ORIGINAL An image whose pixel size is based on the original image (pre-normalized image or normalized image).

DERIVED An image derived from pixel size of one or more images according to a specific method. (processed image).

(In cases of Digital Mammography X-ray Image Storage – For Presentation and Digital Mammography X-Ray Image Storage – For Processing)

ORIGINAL An image whose pixel size is based on the original image(include processed image).

DERIVED An image derived from pixel size of one or more images according to a morphological method(energy subtraction processing or image composition processing).

Value 2: (as per DICOM definitions)

PRIMARY An image generated as a direct result from a patient study.

SECONDARY An image generated after the first patient study.

Value 3:

(In cases of Computed Radiography Image Storage and FUJI Private Computed Radiography Image Storage)

PRE_NORMALIZED A pre-normalized image.

NORMALIZED A normalized image.

POST_PROCESSED An already processed image. (include pre-normalized and processed image)

(In cases of Digital Mammography X-ray Image Storage – For Presentation and Digital Mammography X-Ray Image Storage – For Processing)

N/A

Value 4:

RT Routine exposure image

ES_L Low-pressure image for energy subtraction processing.

ES_H High-pressure image for energy subtraction processing.

Value 5:

RENORMALIZED A re-normalized image.

MODIFIED_PARAM An image on which image processing parameters have been modified.

Value 6 and Value 8:

Determine in the “YYYYMMDDhhmmss” format a date when image processing was performed.

Value 7:

STICHED Image composition processing that generates one image from multiple images.

BONE A bone image based on the energy subtraction processing.

SOFT_TISSUE Soft tissue image based on the energy subtraction processing.

Value 9:

The distance (nm) between the centers of each pixel when an IP is read.

When “RENORMALIZED” has been determined for Value 5, what is determined will not be changed even if parameters were modified.

Note 2: The CR and MG image is a projected image and Imager Pixel Spacing (0018,1164) must be used for the distance between the centers of each pixel. However, because some workstations perform necessary processing based on Pixel Spacing (0028,0030), such distance on the Detector surface is determined for it.

According to DICOM definitions, the Pixel Spacing (0028,0030) is to represent the distance between the centers of each pixel in the “patient’s body”. Because the CR and MG image is a projected image, it is not possible to calculate the distance between the centers of each pixel “in the patient’s body”.

Therefore, the value determined here is not correct in the light of the DICOM definitions. Note that even if the distance, area or dimensions are calculated based on the value presented here, the resultant values thus calculated do not precisely reflect an object in the patient’s body.

(Remember that the CR and MG image is a projected image, which disables measurements of the dimensions of the object precisely reflected by actual dimensions in the patient’s body.)

Note 3: 1. This applies not only to images with a known relationship to a 3D space, but also to projection images. For example, a projection radiograph such as a mammogram that is processed by a point image processing operation such as contrast enhancement, or a smoothing or edge enhancing convolution, would have a value of YES for this attribute. A projection radiograph that had been magnified or warped geometrically would have a value of NO for this attribute. A projection radiograph that has been flipped, and/or rotated by a multiple of 90 degrees, such that transformation of pixel locations is possible by comparison of the values of Patient Orientation (0020,0020) would have a value of REORIENTED_ONLY. This attribute is typically of importance in relating images with Presentation Intent Type (0008,0068) values of FOR PROCESSING and FOR PRESENTATION.

2. When the value of this attribute is NO, it is not possible to locate on the current image any pixel coordinates that are referenced relative to the source image, such as for example, might be required for rendering CAD findings derived from a referenced FOR PROCESSING image on the current FOR PRESENTATION image.

8.1.1.18 Image Plane Module

TABLE 8.1- 18 IMAGE PLANE MODULE OF CREATED SOP INSTANCES

Attribute Name	Tag	Type	DICOM Attribute Description	Presence of Value	Source
Image Orientation (Patient)	(0020,0037)	1	The direction cosines of the first row and the first column with respect to the patient.	ANAP Only in case of Tomosynthesis reconstructed images and a S-View Image.	Auto
Image Position (Patient)	(0020,0032)	1	The x, y, and z coordinates of the upper left hand corner (center of the first voxel transmitted) of the image, in mm.	ANAP Only in case of Tomosynthesis reconstructed images and a S-View Image. See Note1 below In case of S-View, the value is same as the first reconstructed image.	Auto
Slice Thickness	(0018,0050)	2	Relative position of the image plane expressed in mm.	ANAP Only in case of Tomosynthesis reconstructed images. Not include in S-View	Auto

Note 1:

It is the distance from the detector plane, Origin of coordinates is the upper left corner of the first reconstructed image.

8.1.1.19 Image Pixel Module

TABLE 8.1- 19 IMAGE PIXEL MODULE OF CREATED SOP INSTANCES

Attribute Name	Tag	Type	DICOM Attribute Description	Presence of Value	Source
Samples per Pixel	(0028,0002)	1	Number of samples (planes) in this image. See PS3.3 C.7.6.3.1.1 for further explanation.	ALWAYS Value is "1"	AUTO
Photometric Interpretation	(0028,0004)	1	Specifies the intended interpretation of the pixel data. See PS3.3 C.7.6.3.1.2 for further explanation.	ALWAYS Value is "MONOCHROME1"	AUTO
Rows	(0028,0010)	1	Number of rows in the image.	ALWAYS	AUTO
Columns	(0028,0011)	1	Number of columns in the image	ALWAYS	AUTO
Bits Allocated	(0028,0100)	1	Number of bits allocated for each pixel sample. Each sample shall have the same number of bits allocated. See PS 3.5 for further explanation.	ALWAYS Value is "16"	AUTO
Bits Stored	(0028,0101)	1	Number of bits stored for each pixel sample. Each sample shall have the same number of bits stored. See PS 3.5 for further explanation.	ALWAYS	AUTO
High Bit	(0028,0102)	1	Most significant bit for pixel sample data. Each sample shall have the same high bit. See PS 3.5 for further explanation.	ALWAYS	AUTO
Pixel Representation	(0028,0103)	1	Data representation of the pixel samples. Each sample shall have the same pixel representation. Enumerated Values: 0000H = unsigned integer. 0001H = 2's complement	ALWAYS Value is "0000H"	AUTO

Attribute Name	Tag	Type	DICOM Attribute Description	Presence of Value	Source
Pixel Data	(7FE0,0010)	1C	A data stream of the pixel samples that comprise the Image. Required if Pixel Data Provider URL (0028,7FE0) is not present.	ALWAYS	AUTO
Pixel Padding Range Limit	(0028,0121)	1C	Pixel value that represents one limit (inclusive) of a range of padding values used together with Pixel Padding Value (0028,0120) as defined in the General Equipment Module. See C.7.5.1.1.2 for further explanation. Required if pixel padding is to be defined as a range rather than a single value.	ANAP	AUTO /USER

8.1.1.20 Contrast/Bolus Module

TABLE 8.1- 20 CONTRAST/BOLUS MODULE OF CREATED SOP INSTANCES

Attribute Name	Tag	Type	DICOM Attribute Description	Presence of Value	Source
Contrast/Bolus Agent	(0018,0010)	2	Contrast or bolus agent	EMPTY	AUTO

8.1.1.21 CR Image Module

TABLE 8.1- 21 CR IMAGE MODULE OF CREATED CR IMAGE STORAGE SOP INSTANCES

Attribute Name	Tag	Type	DICOM Attribute Description	Presence of Value	Source
Photometric Interpretation	(0028,0004)	1	Specifies the intended interpretation of the pixel data. Shall have one of the following Enumerated Values: MONOCHROME1 MONOCHROME2	ALWAYS Value is "MONOCHROME1"	AUTO
KVP	(0018,0060)	3	Peak kilo voltage output of the x-ray generator used.	ANAP The result value of the actual exposure will be stored.	AUTO
Plate ID	(0018,1004)	3	The ID or serial number of the sensing plate upon which the image was acquired.	ANAP Format is "a*****c"	AUTO
Exposure Time	(0018,1150)	3	Time of x-ray exposure in msec.	ANAP (FDR-1000AWS / FDR-2000AWS) The sum of the result values of the pre-exposure and actual exposure will be stored. (Only FDR-3000AWS) The result value of the actual exposure will be stored.	AUTO
X-ray Tube Current	(0018,1151)	3	X-ray Tube Current in mA.	ANAP The result value of the actual exposure will be stored.	AUTO

Attribute Name	Tag	Type	DICOM Attribute Description	Presence of Value	Source
Exposure	(0018,1152)	3	The exposure expressed in mAs, for example calculated from Exposure Time and X-ray Tube Current.	ANAP (FDR-1000AWS / FDR-2000AWS) The sum of the result values of the pre-exposure and actual exposure will be stored. (Only FDR-3000AWS) The result value of the actual exposure will be stored.	AUTO
Exposure in μ As	(0018,1153)	3	The exposure expressed in μ As, for example calculated from Exposure Time and X-ray Tube Current.	ANAP (FDR-1000AWS / FDR-2000AWS) The sum of the result values of the pre-exposure and actual exposure will be stored. (Only FDR-3000AWS) The result value of the actual exposure will be stored.	AUTO
Imager Pixel Spacing	(0018,1164)	3	Physical distance measured at the front plane of the Image Receptor housing between the center of each pixel. Specified by a numeric pair - row spacing value (delimiter) column spacing value - in mm. In the case of CR, the front plane is defined to be the external surface of the CR plate closest to the patient and radiation source.	ALWAYS See Note 1 below.	AUTO
Acquisition Device Processing Description	(0018,1400)	3	Describes device-specific processing associated with the image (e.g. Organ Description)	ALWAYS Sets menu name. Exposure menu name.	CONFIG /USER

Attribute Name	Tag	Type	DICOM Attribute Description	Presence of Value	Source
Acquisition Device Processing Code	(0018,1401)	3	Code representing the device-specific processing associated with the image (e.g. CR Organ Filtering code)	ALWAYS Sets menu code. Codifies the body part, exposure method and exposure menu. Taken to be FFFF if no value exists.	CONFIG /USER
Relative X-Ray Exposure	(0018,1405)	3	Relative x-ray exposure on the plate. Meaning of values is implementation specific. May be used to adjust the dynamic range of the plate digitizer (scanner)	ANAP	AUTO
Sensitivity	(0018,6000)	3	Reading sensitivity.	ANAP	AUTO

Note 1: When the pixel density was subjected to change after an IP has been read, it was adjusted appropriately so that the influence of such a change is reflected accordingly. It will always be the distance between the centers of each pixel on the IP surface of the pixel data determined to be the PixelData (7FE0,0010)

8.1.1.22 DX Image Module

TABLE 8.1- 22 DX IMAGE MODULE OF CREATED MG IMAGE STORAGE SOP INSTANCES

Attribute Name	Tag	Type	DICOM Attribute Description	Presence of Value	Source
Image Type	(0008,0008)	1	Image identification characteristics.	ALWAYS See Note 1 below.	AUTO
Samples per Pixel	(0028,0002)	1	Number of samples in this image. Shall have an Enumerated Value of 1.	ALWAYS Value is "1"	AUTO
Photometric Interpretation	(0028,0004)	1	Specifies the intended interpretation of the pixel data. Shall have one of the following Enumerated Values: MONOCHROME1 MONOCHROME2	ALWAYS Value is "MONOCHROME1"	AUTO
Bits Allocated	(0028,0100)	1	Number of bits allocated for each pixel sample. Enumerated Values: 8, 16	ALWAYS Value is "16"	AUTO
Bits Stored	(0028,0101)	1	Number of bits stored for each pixel sample. Enumerated Values: 6 to 16	ALWAYS	AUTO
High Bit	(0028,0102)	1	Most significant bit for pixel sample data. Shall have an Enumerated Value of one less than the value in Bit Stored (0028,0101).	ALWAYS	AUTO
Pixel Representation	(0028,0103)	1	Data representation of the pixel samples. Shall have the Enumerated Value: 0000H = Unsigned Integer.	ALWAYS Value is "0000H"	AUTO
Pixel Intensity Relationship	(0028,1040)	1	The relationship between the Pixel sample values and the X-Ray beam intensity. Enumerated Values: LIN = Linearly proportional to X-Ray beam intensity LOG = Logarithmically proportional to X-ray beam intensity See PS3.3 C.8.11.3.1.2 for further explanation.	ALWAYS	AUTO

Attribute Name	Tag	Type	DICOM Attribute Description	Presence of Value	Source
Pixel Intensity Relationship Sign	(0028,1041)	1	The sign of the relationship between the Pixel sample values stored in Pixel Data (7FE0,0010) and the X-Ray beam intensity. Enumerated Values; 1 = Lower pixel values correspond to less X-Ray beam intensity -1 = Higher pixel values correspond to less X-Ray beam intensity See PS3.3 C.8.11.3.1.2 for further explanation.	ALWAYS Value is "-1"	AUTO
Rescale Intercept	(0028,1052)	1	The value b in the relationship between stored values (SV) in Pixel Data (7FE0,0010) and the output units specified in Rescale Type (0028,1054). Output units = m*SV + b. Enumerated Value: 0 See PS3.3 C.8.11.3.1.2 for further explanation.	ALWAYS Value is "0"	AUTO
Rescale Slope	(0028,1053)	1	m in the equation specified by Rescale Intercept (0028,1052). Enumerated Value: 1 See PS3.3 C.8.11.3.1.2 for further explanation.	ALWAYS Value is "1"	AUTO
Rescale Type	(0028,1054)	1	Specifies the output units of Rescale Slope (0028,1053) and Rescale Intercept (0028,1052). Enumerated Value: US = Unspecified See PS3.3 C.8.11.3.1.2 for further explanation.	ALWAYS Value is "US"	AUTO

Attribute Name	Tag	Type	DICOM Attribute Description	Presence of Value	Source
Presentation LUT Shape	(2050,0020)	1	<p>Specifies an identity transformation for the Presentation LUT, other than to account for the value of Photometric Interpretation (0028,0004), such that the output of all grayscale transformations defined in the IOD containing this Module are defined to be P-Values.</p> <p>Enumerated Values: IDENTITY - output is in P-Values - shall be used if Photometric Interpretation (0028,0004) is MONOCHROME2. INVERSE - output after inversion is in P-Values - shall be used if Photometric Interpretation (0028,0004) is MONOCHROME1.</p> <p>See PS3.3 C.8.11.3.1.2 for further explanation.</p>	<p>ALWAYS</p> <p>Value is "INVERSE"</p>	AUTO
Lossy Image Compression	(0028,2110)	1	<p>Specifies whether an Image has undergone lossy compression. Enumerated Values: 00 = Image has NOT been subjected to lossy compression. 01 = Image has been subjected to lossy compression.</p> <p>See PS3.3 C.7.6.1.1.5 for further explanation.</p>	<p>ALWAYS</p> <p>Value is "00"</p>	AUTO
Acquisition Device Processing Description	(0018,1400)	3	<p>Indicates any visual processing performed on the images prior to exchange. See PS3.3 C.8.11.3.1.3 for further explanation.</p>	<p>ALWAYS</p> <p>Sets menu name. Exposure menu name.</p>	CONFIG /USER
Acquisition Device Processing Code	(0018,1401)	3	<p>Code representing the device-specific processing associated with the image (e.g. Organ Filtering code)</p>	<p>ALWAYS</p> <p>Sets menu code. Codifies the body part, exposure method and exposure menu. Taken to be FFFF if no value exists.</p>	CONFIG /USER

Attribute Name	Tag	Type	DICOM Attribute Description	Presence of Value	Source
Patient Orientation	(0020,0020)	1	Patient direction of the rows and columns of the image. See PS3.3 C.7.6.1.1.1 for further explanation.	ALWAYS	CONFIG /USER
Burned In Annotation	(0028,0301)	1	Indicates whether or not image contains sufficient burned in annotation to identify the patient and date the image was acquired. Enumerated Values: YES NO	ALWAYS Value is "NO"	AUTO
VOI LUT Sequence	(0028,3010)	1C	Defines a sequence of VOI LUTs. See PS3.3 C.8.11.3.1.5 for further explanation. Required if Presentation Intent Type (0008,0068) is FOR PRESENTATION and Window Center (0028,1050) is not present. May also be present if Window Center (0028,1050) is present.	ANAP	AUTO
>LUT Descriptor	(0028,3002)	1C	Specifies the format of the LUT Data in this Sequence. See PS3.3 C.8.11.3.1.5 for further explanation. Required if the VOI LUT Sequence (0028,3010) is sent.	ANAP	AUTO
>LUT Explanation	(0028,3003)	3	Free form text explanation of the meaning of the LUT.	ANAP	AUTO
>LUT Data	(0028,3006)	1C	LUT Data in this Sequence. Required if the VOI LUT Sequence (0028,3010) is sent.	ANAP	AUTO
Window Center	(0028,1050)	1C	Defines a Window Center for display. See PS3.3 C.8.11.3.1.5 for further explanation. Required if Presentation Intent Type (0008,0068) is FOR PRESENTATION and VOI LUT Sequence (0028,3010) is not present. May also be present if VOI LUT Sequence (0028,3010) is present.	ALWAYS	AUTO

Attribute Name	Tag	Type	DICOM Attribute Description	Presence of Value	Source
Window Width	(0028,1051)	1C	Window Width for display. See PS3.3 C.8.11.3.1.5 for further explanation. Required if Window Center (0028,1050) is sent.	ALWAYS	AUTO
Window Center & Width Explanation	(0028,1055)	3	Free form explanation of the meaning of the Window Center and Width. Multiple values correspond to multiple Window Center and Width values.	ANAP	AUTO

Note 1:

See 8.1.1.17 Note however that Value 1 and Value 3 are as follows.

Value 1: (as per DICOM definitions)

- ORIGINAL Normalized image (an exposed image that has been subjected to image processing, such as gradation processing.)
- DERIVED An image created through morphological processing (long-view image, energy subtraction image).

Value 3:

None.

8.1.1.23 Mammography Image Module

TABLE 8.1- 23 MAMMOGRAPHY IMAGE MODULE OF CREATED MG IMAGE STORAGE SOP INSTANCES

Attribute Name	Tag	Type	DICOM Attribute Description	Presence of Value	Source
Positioner Type	(0018,1508)	1	Enumerated Values: MAMMOGRAPHIC NONE	ALWAYS Value is "MAMMOGRAPHIC"	AUTO
Positioner Primary Angle	(0018,1510)	3	Position in degrees of the X-Ray beam vector in the coronal anatomical plane as if the patient were standing where movement of the X-Ray source from right to vertical is positive, and vertical is zero.	ANAP	AUTO
Positioner Secondary Angle	(0018,1511)	3	Position in degrees of the X-Ray beam vector in the sagittal anatomical plane as if the patient were standing where movement of the X-Ray source from anterior to posterior is positive, and vertical is zero.	ANAP	AUTO
Image Laterality	(0020,0062)	1	Laterality of the region examined. Enumerated Values: R = right L = left B = both (e.g. cleavage)	ALWAYS	CONFIG /USER
Organ Exposed	(0040,0318)	1	Organ to which Organ Dose (0040,0316) applies. Enumerated Value: BREAST	ALWAYS Value is "BREAST"	AUTO
Implant Present	(0028,1300)	3	Whether or not an implant is present. Enumerated Values: YES NO	ANAP	USER
Anatomic Region Sequence	(0008,2218)	1	Sequence that identifies the anatomic region of interest in this Instance (i.e. external anatomy, surface anatomy, or general region of the body). Only a single Item shall be permitted in this sequence.	ALWAYS	CONFIG /USER

Attribute Name	Tag	Type	DICOM Attribute Description	Presence of Value	Source
>Code Value	(0008,0100)	1C	Required if a sequence item is present.	ALWAYS Value is "T-4000"	AUTO
>Coding Scheme Designator	(0008,0102)	1C	Required if a sequence item is present.	ALWAYS Value is "SNM3"	AUTO
>Coding Scheme Version	(0008,0103)	1C	Required if a sequence item is present. Required if the value of Coding Scheme Designator (0008,0102) is not sufficient to identify the Code Value (0008,0100) unambiguously.	ANAP	AUTO
>Code Meaning	(0008,0104)	1C	Required if a sequence item is present.	ALWAYS Value is "BREAST"	AUTO
Partial View	(0028,1350)	3	Indicates whether this image is a partial view, that is a subset of a single view of the breast. Enumerated Values: YES, NO If this Attribute is absent, then the image may or may not be a partial view.	ANAP Value is "NO"	AUTO
View Code Sequence	(0054,0220)	1	Sequence that describes the projection of the anatomic region of interest on the image receptor. Only a single Item shall be permitted in this Sequence.	ALWAYS	AUTO
>Code Value	(0008,0100)	1C	Required if a sequence item is present.	ALWAYS	AUTO
>Coding Scheme Designator	(0008,0102)	1C	Required if a sequence item is present.	ALWAYS	AUTO
>Coding Scheme Version	(0008,0103)	1C	Required if a sequence item is present. Required if the value of Coding Scheme Designator (0008,0102) is not sufficient to identify the Code Value (0008,0100) unambiguously.	ANAP	AUTO
>Code Meaning	(0008,0104)	1C	Required if a sequence item is present.	ALWAYS	AUTO
>View Modifier Code Sequence	(0054,0222)	2	View modifier. Zero or more Items may be included in this Sequence.	VNAP See DICOM PS 3.16 -2011 Page 492.	AUTO

Attribute Name	Tag	Type	DICOM Attribute Description	Presence of Value	Source
>>Code Value	(0008,0100)	1C	Required if a sequence item is present.	ANAP	AUTO
>>Coding Scheme Designator	(0008,0102)	1C	Required if a sequence item is present.	ANAP	AUTO
>>Coding Scheme Version	(0008,0103)	1C	Required if a sequence item is present. Required if the value of Coding Scheme Designator (0008,0102) is not sufficient to identify the Code Value (0008,0100) unambiguously.	ANAP	AUTO
>>Code Meaning	(0008,0104)	1C	Required if a sequence item is present.	ANAP	AUTO

8.1.1.24 DX Detector Module

TABLE 8.1- 24 DX DETECTOR MODULE OF CREATED MG IMAGE STORAGE SOP INSTANCES

Attribute Name	Tag	Type	DICOM Attribute Description	Presence of Value	Source
Detector Type	(0018,7004)	2	The type of detector used to acquire this image. Defined Terms: DIRECT = X-Ray photoconductor SCINTILLATOR = Phosphor used STORAGE = Storage phosphor FILM = Scanned film/screen	ALWAYS Value is "STORAGE"	AUTO
Detector Configuration	(0018,7005)	3	The physical configuration of the detector. Defined Terms: AREA = single or tiled detector SLOT = scanned slot, slit or spot	ALWAYS Value is "SLOT"	AUTO
Detector ID	(0018,700A)	3	The ID or serial number of the detector used to acquire this image.	ANAP	CONFIG /AUTO
Date of Last Detector Calibration	(0018,700C)	3	The date on which the detector used to acquire this image as identified in Detector ID (0018,700A) was last calibrated.	ANAP	AUTO
Sensitivity	(0018,6000)	3	Detector sensitivity in manufacturer specific units.	ANAP	AUTO
Field of View Shape	(0018,1147)	3	Shape of the Field of View, that is the image pixels stored in Pixel Data (7FE0,0010). Enumerated Values: RECTANGLE ROUND HEXAGONAL	ALWAYS Value is "RECTANGLE"	AUTO

Attribute Name	Tag	Type	DICOM Attribute Description	Presence of Value	Source
Field of View Dimension(s)	(0018,1149)	3	Dimensions in mm of the Field of View, that is the image pixels stored in Pixel Data (7FE0,0010). If Field of View Shape (0018,1147) is: RECTANGLE: row dimension followed by column. ROUND: diameter. HEXAGONAL: diameter of a circumscribed circle.	ALWAYS	AUTO
Imager Pixel Spacing	(0018,1164)	1	Physical distance measured at the front plane of the detector housing between the center of each image pixel specified by a numeric pair - row spacing value(delimiter) column spacing value in mm. See PS3.3 10.7.1.3 for further explanation of the value order. The value of this attribute shall never be adjusted to account for correction for the effect of geometric magnification or calibration against an object of known size; Pixel Spacing (0028,0030) is specified for that purpose.	ALWAYS	AUTO

8.1.1.25 DX Positioning Module

TABLE 8.1- 25 DX POSITIONING MODULE OF CREATED SOP INSTANCES

Attribute Name	Tag	Type	DICOM Attribute Description	Presence of Value	Source
Estimated Radiographic Magnification Factor	(0018,1114)	3	Ratio of Source Image Receptor Distance (SID) over Source Object Distance (SOD).	ALWAYS Set to 1.0 or 1.8.	AUTO
Positioner Type	(0018,1508)	2	Defined Terms: CARM, COLUMN, MAMMOGRAPHIC, PANORAMIC, CEPHALOSTAT, RIGID,NONE	ALWAYS When CR is used for Modality (0008,0060), Value is "NONE" When MG is used for Modality (0008,0060), Value is "MAMMOGRAPHIC"	AUTO
Positioner Primary Angle	(0018,1510)	3	Position of the X-Ray beam about the patient from the RAO to LAO direction where movement from RAO to vertical is positive, if Positioner Type (0018,1508) is CARM. See PS3.3 C.8.11.7 Mammography Image Module for explanation if Positioner Type (0018,1508) is MAMMOGRAPHIC.	ANAP	AUTO
Body Part Thickness	(0018,11A0)	3	The average thickness in mm of the body part examined when compressed, if compression has been applied during exposure.	ANAP	AUTO
Compression Force	(0018,11A2)	3	The compression force applied to the body part during exposure, measured in Newtons.	ANAP	AUTO
Paddle Description	(0018,11A4)	3	Description of the compression paddle, if compression was applied to thebody part during exposure.	ANAP	AUTO

8.1.1.26 X-ray Tomography Acquisition Module

TABLE 8.1- 26 X-RAY TOMOGRAPHY ACQUISITION MODULE OF CREATED MG IMAGE STORAGE SOP INSTANCES

Attribute Name	Tag	Type	Dicom Attribute Description	Presence of Value	Source
Tomography Layer Height	(0018,1460)	1	Distance in mm between the table surface and the sharp image plane.	ALWAYS Value is in the range from -6 to 160.	AUTO
Tomography Angle	(0018,1470)	3	Angle span in degrees of rotation of X-ray Source during X-ray acquisition.	ANAP	AUTO
Tomography Time	(0018,1480)	3	Time in seconds the source has taken to rotate the Tomography Angle during X-ray acquisition.	ANAP	AUTO
Tomography Type	(0018,1490)	3	Type of tomography. Defined Terms: LINEAR SPIRAL POLYCYCLOIDAL CIRCULAR	ANAP Only in case of Tomosynthesis. Value is "LINEAR"	AUTO
Tomography Class	(0018,1491)	3	Form of tomography: Defined Terms: MOTION TOMOSYNTHESIS	ANAP Only in case of Tomosynthesis. Value is "TOMOSYNTHESIS"	AUTO
Number of Tomosynthesis Source Images	(0018,1495)	3	The number of source images used to construct this tomosynthetic image. Only meaningful if Tomography Class (0018,1491) is TOMOSYNTHESIS. These may be listed in Source Image Sequence (0008,2112) of the General Image Module.	ANAP	AUTO

8.1.1.27 X-Ray Acquisition Dose Module

TABLE 8.1- 27 X-RAY ACQUISITION DOSE MODULE OF CREATED SOP INSTANCES

Attribute Name	Tag	Type	DICOM Attribute Description	Presence of Value	Source
KVP	(0018,0060)	3	Peak kilo voltage output of the X-Ray generator used.	ANAP The result value of the actual exposure will be stored.	AUTO
X-Ray Tube Current	(0018,1151)	3	X-Ray Tube Current in mA.	ANAP The result value of the actual exposure will be stored.	AUTO
Exposure Time	(0018,1150)	3	Duration of X-Ray exposure in msec.	ANAP (FDR-1000AWS / FDR-2000AWS) The sum of the result values of the pre-exposure and actual exposure will be stored. (Only FDR-3000AWS) The result value of the actual exposure will be stored.	AUTO
Exposure	(0018,1152)	3	The exposure expressed in mAs, for example calculated from Exposure Time and X-ray Tube Current.	ANAP (FDR-1000AWS / FDR-2000AWS) The sum of the result values of the pre-exposure and actual exposure will be stored. (Only FDR-3000AWS) The result value of the actual exposure will be stored.	AUTO

Attribute Name	Tag	Type	DICOM Attribute Description	Presence of Value	Source
Exposure in μ As	(0018,1153)	3	The exposure expressed in μ As, for example calculated from Exposure Time and X-ray Tube Current.	ANAP (FDR-1000AWS / FDR-2000AWS) The sum of the result values of the pre-exposure and actual exposure will be stored. (Only FDR-3000AWS) The result value of the actual exposure will be stored.	AUTO
Distance Source to Detector	(0018,1110)	3	Distance in mm from source to detector center.	ANAP	AUTO
Image and Fluoroscopy Area Dose Product	(0018,115E)	3	X-Ray dose, measured in dGy*cm*cm, to which the patient was exposed for the acquisition of this image plus any nondigitally recorded fluoroscopy which may have been performed to prepare for the acquisition of this image.	ANAP	AUTO
Relative X-Ray Exposure	(0018,1405)	3	Indication of the applied dose, in manufacturer specific units. Notes: 1. This value is intended to provide a single location where manufacturer specific information can be found for annotation on a display or film, that has meaning to a knowledgeable observer. 2. This may be a calculated or measured value. Examples are the detector entrance dose (KB), the CR sensitivity value (S), or the logarithmic median (lgM).	ANAP	AUTO

Attribute Name	Tag	Type	DICOM Attribute Description	Presence of Value	Source
Body Part Thickness	(0018,11A0)	3	The average thickness in mm of the body part examined when compressed, if compression has been applied during exposure.	ANAP	AUTO
Entrance Dose	(0040,0302)	3	Average entrance dose value measured in dGy at the surface of the patient during the acquisition of this image.	ANAP In case Tomosynthesis (including Reconstructed and S-View), the value is the total of 15 projection images	AUTO
Entrance Dose in mGy	(0040,8302)	3	Average entrance dose value measured in mGy at the surface of the patient during the acquisition of this image.	ANAP In case Tomosynthesis (including Reconstructed and S-View), the value is the total of 15 projection images	AUTO
Organ Dose	(0040,0316)	3	Average organ dose value measured in dGy during the acquisition of this image.	ANAP In case Tomosynthesis (including Reconstructed and S-View), the value is the total of 15 projection images	AUTO
Anode Target Material	(0018,1191)	3	The primary material in the anode of the X-Ray source. Defined Terms: TUNGSTEN MOLYBDENUM RHODIUM	ANAP	AUTO
Filter Material	(0018,7050)	3	The X-Ray absorbing material used in the filter. May be multi-valued. Defined Terms: MOLYBDENUM ALUMINUM COPPER RHODIUM NIOBIUM EUROPIUM LEAD	ANAP	AUTO

8.1.1.28 X-Ray Generation Module

TABLE 8.1- 28 X-RAY GENERATION MODULE OF CREATED SOP INSTANCES

Attribute Name	Tag	Type	DICOM Attribute Description	Presence of Value	Source
KVP	(0018,0060)	3	Peak kilo voltage output of the X-Ray generator used.	ANAP	AUTO
X-Ray Tube Current	(0018,1151)	3	X-Ray Tube Current in mA.	ANAP	AUTO
Exposure Time	(0018,1150)	3	Duration of X-Ray exposure in msec.	ANAP	AUTO
Exposure	(0018,1152)	3	The exposure expressed in mAs, for example calculated from Exposure Time and X-ray Tube Current.	ANAP	AUTO
Exposure in μ As	(0018,1153)	3	The exposure expressed in μ As, for example calculated from Exposure Time and X-ray Tube Current.	ANAP	AUTO
Exposure Control Mode	(0018,7060)	3	Type of exposure control. Defined Terms: MANUAL AUTOMATIC	ANAP	AUTO
Exposure Control Mode Description	(0018,7062)	3	Text description of the mechanism of exposure control. May describe the number and type of exposure sensors or position of the sensitive area of the imaging detector.	ANAP	AUTO
Anode Target Material	(0018,1191)	3	The primary material in the anode of the X-Ray source. Defined Terms: TUNGSTEN MOLYBDENUM RHODIUM	ANAP	AUTO

8.1.1.29 X-Ray Grid Module

TABLE 8.1- 29 X-RAY GRID MODULE OF CREATED SOP INSTANCES

Attribute Name	Tag	Type	DICOM Attribute Description	Presence of Value	Source
Grid	(0018,1166)	3	Identifies the grid. May be multi-valued. Defined Terms are: FIXED FOCUSED RECIPROCATING PARALLEL CROSSED NONE USED	ALWAYS Sets whether the grid is used or not. USED: Grid is used. NONE: Grid is not used.	AUTO

8.1.1.30 Modality LUT Module

TABLE 8.1- 30 MODALITY LUT MODULE OF CREATED CR IMAGE STORAGE SOP INSTANCES

Attribute Name	Tag	Type	DICOM Attribute Description	Presence of Value	Source
Rescale Intercept	(0028,1052)	1C	The value b in relationship between stored values (SV) and the output units specified in Rescale Type (0028,1054). Output units = m*SV + b. Required if Modality LUT Sequence (0028,3000) is not present. Shall not be present otherwise.	ALWAYS Value is "0"	AUTO
Rescale Slope	(0028,1053)	1C	m in the equation specified by Rescale Intercept (0028,1052). Required if Rescale Intercept is present.	ALWAYS Value is "1"	AUTO
Rescale Type	(0028,1054)	1C	Specifies the output units of Rescale Slope (0028,1053) and Rescale Intercept (0028,1052). See PS3.3 C.11.1.1.2 for further explanation. Required if Rescale Intercept is present.	ALWAYS Value is "US"	AUTO
Modality LUT Sequence	(0028,3000)	1C	Defines a sequence of Modality LUTs. Only one Item may be present. Shall not be present if Rescale Intercept (0028,1052) is present.	ANAP	AUTO
>LUT Descriptor	(0028,3002)	1C	Specifies the format of the LUT Data in this Sequence. See PS3.3 C.11.1.1 for further explanation. Required if the Modality LUT Sequence (0028,3000) is sent.	ANAP 2 ⁿ \0\16 n :Bit Depth of image	AUTO
>LUT Explanation	(0028,3003)	3	Free form text explanation of the meaning of the LUT.	ANAP	AUTO
>Modality LUT Type	(0028,3004)	1C	Specifies the output values of this Modality LUT. See PS3.3 C.11.1.1.2 for further explanation. Required if the Modality LUT Sequence (0028,3000) is sent.	ANAP Value is "US"	AUTO

Attribute Name	Tag	Type	DICOM Attribute Description	Presence of Value	Source
>LUT Data	(0028,3006)	1C	LUT Data in this Sequence. Required if the Modality LUT Sequence (0028,3000) is sent.	ANAP	AUTO

8.1.1.31 VOI LUT Module

TABLE 8.1- 31 VOI LUT MODULE OF CREATED SOP INSTANCES

Attribute Name	Tag	Type	DICOM Attribute Description	Presence of Value	Source
VOI LUT Sequence	(0028,3010)	1C	Defines a sequence of VOI LUTs. One or more Items shall be present. Required if Window Center (0028,1050) is not present. May be present otherwise.	ANAP	AUTO
>LUT Descriptor	(0028,3002)	1C	Specifies the format of the LUT Data in this Sequence. See C.11.2.1.1 for further explanation.	ANAP $2^n \setminus 16$ n :Bit Depth of image	AUTO
>LUT Explanation	(0028,3003)	3	Free form text explanation of the meaning of the LUT.	ANAP	AUTO
>LUT Data	(0028,3006)	1C	LUT Data in this Sequence.	ANAP	AUTO
Window Center	(0028,1050)	1C	Defines a Window Center for display. See PS3.3 C.8.11.3.1.5 for further explanation. Required if Presentation Intent Type (0008,0068) is FOR PRESENTATION and VOI LUT Sequence (0028,3010) is not present. May also be present if VOI LUT Sequence (0028,3010) is present.	ALWAYS	AUTO
Window Width	(0028,1051)	1C	Window Width for display. See PS3.3 C.8.11.3.1.5 for further explanation. Required if Window Center (0028,1050) is sent.	ALWAYS	AUTO
Window Center & Width Explanation	(0028,1055)	3	Free form explanation of the meaning of the Window Center and Width. Multiple values correspond to multiple Window Center and Width values.	ANAP	AUTO

Attribute Name	Tag	Type	DICOM Attribute Description	Presence of Value	Source
VOI LUT Function	(0028,1056)	3	<p>Describes a VOI LUT function to apply to the values of Window Center (0028,1050) and Window Width (0028,1051). See DICOM PS3.3 C.11.2.1.3 for further explanation.</p> <p>Defined terms: LINEAR SIGMOID</p> <p>When this attribute is not present, the interpretation of the values of Window Center (0028,1050) and Window Width (0028,1051) is linear as in DICOM PS3.3 C.11.2.1.2.</p>	ANAP Value is "LINEAR"	AUTO

8.1.1.32 Acquisition Context Module

TABLE 8.1- 32 ACQUISITION CONTEXT MODULE OF CREATED MG IMAGE STORAGE SOP INSTANCES

Attribute Name	Tag	Type	DICOM Attribute Description	Presence of Value	Source
Acquisition Context Sequence	(0040,0555)	2	A sequence of Items that describes the conditions present during the acquisition of the data of the SOP Instance. Zero or more items may be included in this sequence.	EMPTY	AUTO

8.1.1.33 Multi-frame Functional Groups Module

TABLE 8.1- 33 MULTI-FRAME FUNCTIONAL GROUPS MODULE OF CREATED BREAST TOMOSYNTHESIS IMAGE STORAGE SOP INSTANCES

Attribute Name	Tag	Type	DICOM Attribute Description	Presence of Value	Source
Shared Functional Groups Sequence	(5200,9229)	2	Sequence that contains the Functional Group Macros that are shared for all frames in this SOP Instance and Concatenation. Note: The contents of this sequence are the same in all SOP Instances that comprise a Concatenation. Zero or one Item shall be included in this sequence.	VNAP	AUTO
<p>>Include one or more Functional Group Macros that are shared by all frames. The selected Functional Group Macros shall not be present in the Per-frame Functional Groups Sequence (5200,9230). See Table 8.1- 34</p>			<p>For each IOD that includes this module, a table is defined in which the permitted Functional Group Macros and their usage is specified.</p>		
Per-frame Functional Groups Sequence	(5200,9230)	1	Sequence that contains the Functional Group Sequence Attributes corresponding to each frame of the Multi-frame Image. The first Item corresponds with the first frame, and so on. One or more Items shall be included in this sequence. The number of Items shall be the same as the number of frames in the Multi-frame image.	ALWAYS One Item for S-View	AUTO
<p>>Include one or more Functional Group Macros. See Table 8.1- 34</p>			<p>For each IOD that includes this module, a table is defined in which the permitted Functional Group Macros and their usage is specified.</p>		
Instance Number	(0020,0013)	1	A number that identifies this instance. The value shall be the same for all SOP Instances of a Concatenation, and different for each separate Concatenation and for each SOP Instance not within a Concatenation in a series.	ALWAYS	AUTO

Attribute Name	Tag	Type	DICOM Attribute Description	Presence of Value	Source
Content Date	(0008,0023)	1	The date the data creation was started. Note: For instance, this is the date the pixel data is created, not the date the data is acquired.	ALWAYS	AUTO
Content Time	(0008,0033)	1	The time the data creation was started. The time the data creation was started. Note: For instance, this is the time the pixel data is created, not the time the data is acquired.	ALWAYS	AUTO
Number of Frames	(0028,0008)	1	Number of frames in a multi-frame image.	ALWAYS In the case of the config that a multi-frame image is outputted one by one, the value is "1". In case S-View, the value is "1".	AUTO

Attribute Name	Tag	Type	DICOM Attribute Description	Presence of Value	Source
Concatenation Frame Offset Number	(0020,9228)	1C	Offset of the first frame in a multi-frame image of a concatenation. Logical frame numbers in a concatenation can be used across all its SOP instances. This offset can be applied to the implicit frame number to find the logical frame number in a concatenation. The offset is numbered from zero; i.e., the instance of a concatenation that begins with the first frame of the concatenation has a Concatenation Frame Offset Number (0020,9228) of zero. Required if Concatenation UID (0020,9161) is present.	ALWAYS See Note below. Not include in S-View	AUTO
Concatenation UID	(0020,9161)	1C	Identifier of all SOP Instances that belong to the same concatenation. Required if a group of multi-frame image SOP Instances within a Series are part of a Concatenation.	ALWAYS See Note below. Not include in S-View	AUTO
SOP Instance UID of Concatenation Source	(0020,0242)	1C	The SOP Instance UID of the single composite SOP Instance of which the Concatenation is a part. All SOP Instances of a concatenation shall use the same value for this attribute. Note: May be used to reference the entire instance rather than individual instances of the concatenation, which may be transient (e.g., from a presentation state). Required if Concatenation UID (0020,9161) is present.	ALWAYS See Note below. Not include in S-View	AUTO

Attribute Name	Tag	Type	DICOM Attribute Description	Presence of Value	Source
In-Concatenation Number	(0020,9162)	1C	Identifier for one SOP Instance belonging to a concatenation. The first instance in a concatenation (that with the lowest Concatenation Frame Offset Number (0020,9228) value) shall have an Inconcatenation Number (0020,9162) value of 1, and subsequent instances shall have values monotonically increasing by 1. Required if Concatenation UID (0020,9161) is present.	ALWAYS See Note below. Not include in S-View	AUTO
Pixel Spacing	(0028,0030)	3	Extended Attribute. Physical distance, within the patient, between the centers of each pixel. Expressed as a numerical set: space between adjoining rows (delimiter), space between adjoining columns. Unit: mm.	ANAP If the Field Service Engineer configured that multi-frame image is outputted one by one via the Service/Installation Tool, this attribute is outputted.	AUTO

Note : Other than connected data of the multi-frame image is output and the capacity of dicom data is more than config value, not include.

TABLE 8.1- 34 FUNCTIONAL GROUP MACROS ATTRIBUTES

Attribute Name	Tag	Type	DICOM Attribute Description	Presence of Value	Source
Pixel Measures Macro					
Pixel Measures Sequence	(0028,9110)	1	Identifies the physical characteristics of the pixels of this frame. Only a single Item shall be included in this sequence.	ALWAYS	AUTO

Attribute Name	Tag	Type	DICOM Attribute Description	Presence of Value	Source
>Pixel Spacing	(0028,0030)	1C	Physical distance in the imaging target (patient, specimen, or phantom) between the centers of each pixel, specified by a numeric pair - adjacent row spacing (delimiter) adjacent column spacing in mm. See 10.7.1.3 for further explanation of the value order.	ALWAYS See 8.1.1.17 Note2	AUTO
>Slice Thickness	(0018,0050)	1C	Nominal reconstructed slice thickness (for tomographic imaging) or depth of field (for optical non-tomographic imaging), in mm. Note: Depth of field may be an extended depth of field created by focus stacking (see C.8.12.4). Required if Volumetric Properties (0008,9206) is VOLUME or SAMPLED. May be present otherwise.	ALWAYS Note 1.S-View contains same values as the associated reconstructed slices. 2.This Value sets thin reconstructed slices or thick reconstructed slices.	AUTO
Frame Content Macro					
Frame Content Sequence	(0020,9111)	1	Identifies general characteristics of this frame. Only a single Item shall be included in this sequence.	ALWAYS	AUTO
>Frame Acquisition Number	(0020,9156)	3	A number identifying the single continuous gathering of data over a period of time that resulted in this frame.	ALWAYS	AUTO
Plane Position (Patient) Macro					
Plane Position Sequence	(0020,9113)	1	Identifies the position of the plane of this frame. Only a single Item shall be included in this sequence.	ALWAYS	AUTO
> Image Position	(0020,0032)	1C	The x, y, and z coordinates of the upper left hand corner (center of the first voxel transmitted) of the frame, in mm.	ALWAYS	AUTO
Plane Orientation (Patient) Macro					

Attribute Name	Tag	Type	DICOM Attribute Description	Presence of Value	Source
Plane Orientation Sequence	(0020,9116)	1	Identifies orientation of the plane of this frame. Only a single Item shall be included in this sequence.	ALWAYS	AUTO
> Image Orientation	(0020,0037)	1C	The direction cosines of the first row and the first column with respect to the patient.	ALWAYS	AUTO
Derivation Image Macro					
Derivation Image Sequence	(0008,9124)	2	The set of Images or other composite SOP Instances that were used to derive this frame. Zero or more Items shall be included in this Sequence.	VNAP	AUTO
>Derivation Code Sequence	(0008,9215)	1	A coded description of how this frame was derived. One or more Items shall be included in this Sequence. More than one Item indicates that successive derivation steps have been applied.	VNAP	AUTO
>>Code Value	(0008,0100)	1	Required if a sequence item is present.	VNAP Value is "113074"	AUTO
>>Code Scheme Designator	(0008,0102)	1	Required if a sequence item is present.	VNAP Value is "DCM"	AUTO
>>Code Meaning	(0008,0104)	1	Required if a sequence item is present. Required if the value of Coding Scheme Designator (0008,0102) is not sufficient to identify the Code Value (0008,0100) unambiguously.	VNAP Value is "Volume rendering"	AUTO
>Source Image Sequence	(0008,2112)	2	The set of Images or other Composite SOP Instances that were used to derive this frame. Zero or more Items shall be included in this Sequence.	VNAP In case Tomosynthesis (including Reconstructed and S-View), the value is empty(zero length).	AUTO
Frame Anatomy Macro					
Frame Anatomy Sequence	(0020,9071)	1	Identifies anatomic characteristics of this frame. Only a single Item shall be included in this sequence.	ALWAYS	AUTO

Attribute Name	Tag	Type	DICOM Attribute Description	Presence of Value	Source
>Frame Laterality	(0020,9072)	1	Laterality of (possibly paired) body parts (as described in Anatomic Region Sequence (0008,2218)) examined. Enumerated Values: R = right L = left U = unpaired B = both left and right Note: This Attribute is mandatory, in order to ensure that frames may be positioned correctly relative to one another for display. Shall be consistent with any laterality information contained in Primary Anatomic Structure Modifier Sequence (0008,2230), if present.	ALWAYS	AUTO
Anatomic Region Sequence	(0008,2218)	1	Sequence that identifies the anatomic region of interest in this Instance (i.e. external anatomy, surface anatomy, or general region of the body). Only a single Item shall be permitted in this sequence.	ALWAYS	CONFIG /USER
Identity Pixel Value Transformation Macro					
Pixel value Transformation Sequence	(0028,9145)	1	Contains the attributes involved in the transformation of stored pixel values. Only a single Item shall be included in this sequence.	ALWAYS	AUTO
>Rescale Intercept	(0028,1052)	1	The value b in relationship between stored values (SV) and the output units. Output units = m*SV + b. Enumerated Value: 0	ALWAYS Value is "0".	AUTO
>Rescale Slope	(0028,1053)	1	m in the equation specified by Rescale Intercept (0028,1052). Enumerated Value: 1	ALWAYS Value is "1".	AUTO

Attribute Name	Tag	Type	DICOM Attribute Description	Presence of Value	Source
>Rescale Type	(0028,1054)	1	Specifies the output units of Rescale Slope (0028,1053) and Rescale Intercept (0028,1052). See C.11.1.1.2 for further explanation. Enumerated Value: US - Unspecified	ALWAYS Value is "US".	AUTO
Frame VOI LUT with LUT Macro					
Frame VOI LUT Sequence	(0028,9132)	1	The VOI LUT transformations applied to this frame. Only a single item is permitted in this sequence.	ALWAYS	AUTO
>VOI LUT Sequence	(0028,3010)	1C	Defines a sequence of VOI LUTs. One or more Items shall be included in this sequence. Required if Window Center (0028,1050) is not present. May be present otherwise.	ALWAYS	AUTO
Window Center	(0028,1050)	1C	Window Center for display. Required if VOI LUT Sequence (0028,3010) is not present. May be present otherwise.	ALWAYS	AUTO
Window Width	(0028,1051)	1C	Window Width for display.	ALWAYS	AUTO
VOI LUT Function	(0028,1056)	3	Describes a VOI LUT function to apply to the values of Window Center (0028,1050) and Window Width (0028,1051). See C.11.2.1.3 for further explanation. Defined terms: LINEAR SIGMOID When this attribute is not present, the interpretation of the values of Window Center (0028,1050) and Window Width (0028,1051) is linear.	ANAP	AUTO
X-Ray 3D Frame Type Macro					

Attribute Name	Tag	Type	DICOM Attribute Description	Presence of Value	Source
X-Ray 3D Frame Type Sequence	(0018,9504)	1	A sequence that describes general characteristics of this frame. Only a single Item shall be included in this sequence.	ALWAYS	AUTO
>Frame Type	(0008,9007)	1	Type of Frame. A multi-valued attribute analogous to the Image Type (0008,0008). Enumerated Values and Defined Terms are the same as those for the four values of the Image Type (0008,0008) attribute, except that the value MIXED is not allowed.	ALWAYS	AUTO
>Pixel Presentation	(0008,9205)	1	Indication of the presence or absence of color information that may be used during rendering. See C.8.16.2.1.1 for a description and Enumerated Values.	ALWAYS	AUTO
>Volumetric Properties	(0008,9206)	1	Indication if geometric manipulations are possible with frames in the SOP Instance.	ALWAYS See 8.1.1.34 Note2	AUTO
>Volume Based Calculation Technique	(0008,9207)	1	Method used for volume calculations with frames in the SOP Instance.	ALWAYS See 8.1.1.34 Note2	AUTO
>Reconstruct Index	(0020,9536)	1C	The Item number of the X-Ray 3D Reconstruction Sequence (0018,9530) that describes the characteristics of the 3D Reconstruction to which this frame is part of. Required if the X-Ray 3D Reconstruction Sequence (0018,9530) is present.	ALWAYS Value is "1"	AUTO
Private					
Tomo Layer Height	(0018,1460)	3	Distance in mm between the table surface and the sharp image plane.	ALWAYS	AUTO

Attribute Name	Tag	Type	DICOM Attribute Description	Presence of Value	Source
Bookmark	(0019,xx48)	3	Indicates the presence or absence of the image bookmarked in Tomosynthesis reconstructed images. Value is: Not bookmarked image: 0 Bookmarked image: 1	ALWAYS	USER
Image No. in the set	(0021,xx40)	3	Image numbers from "01" to "99" within the set of (0021,xx30).	ALWAYS	AUTO
Target Of Out	(50F1,xx16)	3	Information to indicate that the reconstructed image is delivered to PACS. 0: Image not to be delivered 1: Image to be delivered *This value is meaningless for non-Tomo menus.	ANAP	AUTO
Target Of Print	(50F1,xx17)	3	Information to indicate that the reconstructed image is printed. 0: Image not to be printed 1: Image to be printed *This value is meaningless for non-Tomo menus.	ANAP	AUTO

8.1.1.34 X-Ray 3D Image Module

TABLE 8.1- 35 X-RAY 3D IMAGE MODULE OF CREATED BREAST TOMOSYNTHESIS IMAGE STORAGE SOP INSTANCES

Attribute Name	Tag	Type	DICOM Attribute Description	Presence of Value	Source
Image Type	(0008,0008)	1	Image identification characteristics.	ALWAYS See Note1 below.	AUTO
Pixel Presentation	(0008,9205)	1	Indication of the presence or absence of color information that may be used during rendering.	ALWAYS	AUTO
Volumetric Properties	(0008,9206)	1	Indication if geometric manipulations are possible with frames in the SOP Instance.	ALWAYS See Note2 below.	AUTO
Volume Based Calculation Technique	(0008,9207)	1	Method used for volume calculations with frames in the SOP Instance.	ALWAYS See Note2 below.	AUTO
Bits Allocated	(0028,0100)	1	Number of bits allocated for each voxel sample. Each sample shall have the same number of bits allocated. Enumerated Values: 8 and 16.	ALWAYS	AUTO
Bits Stored	(0028,0101)	1	Number of bits stored for each voxel sample. Each sample shall have the same number of bits stored. Enumerated Values: 8 to 16.	ALWAYS	AUTO
High Bit	(0028,0102)	1	Most significant bit for pixel sample data. Each sample shall have the same high bit. Shall be one less than the value in Bits Stored(0028,0101).	ALWAYS	AUTO
Samples per Pixel	(0028,0002)	1	Number of samples (color planes) in this image shall have a value of 1.	ALWAYS	AUTO
Photometric Interpretation	(0028,0004)	1	Specifies the intended interpretation of the voxel data.	ALWAYS Value is "MONOCHROME2"	AUTO

Attribute Name	Tag	Type	DICOM Attribute Description	Presence of Value	Source
Content Qualification	(0018,9004)	1	Content Qualification Indicator Enumerated Values: PRODUCT RESEARCH SERVICE	ALWAYS	AUTO
Burned In Annotation	(0028,0301)	1	Indicates whether or not the image contains sufficient burned in annotation to identify the patient and date the image was acquired. Enumerated Values: NO	ALWAYS	AUTO
Lossy Image Compression	(0028,2110)	1	Specifies whether an Image has undergone lossy compression. Enumerated Values: 00 = Image has NOT been subjected to lossy compression. 01 = Image has been subjected to lossy compression.	ALWAYS	AUTO
Image Comments	(0020,4000)	3	User-defined comments about the image.	ANAP	USER
Presentation LUT Shape	(2050,0020)	1	Specifies a predefined identity transformation for the Presentation LUT such that the output of all grayscale transformations, if any, are defined to be in P-Values. Enumerated Values: IDENTITY = output is in P-Values	ALWAYS	AUTO

Note1:

Image Type(0008,0008) is different Value for each reconstruct images.

	Image Type Value1	Image Type Value2	Image Type Value3	Image Type Value4
Tomosynthesis thin reconstructed slices	DERIVED	PRIMARY	TOMOSYNTHESIS	NONE

Mathematically generated 2D views (S-View)	DERIVED	PRIMARY	TOMOSYNTHESIS	GENERATED_2D
Tomosynthesis thick reconstructed slices	DERIVED	PRIMARY	TOMOSYNTHESIS	MAXIMUM

Note2:

Volumetric Properties(0008,9206) and Volume Based Calculation Technique(0008,9207) are different Values for each Reconstructed Images.

	Volumetric Properties	Volume Based Calculation Technique
Tomosynthesis thin reconstructed slices	VOLUME	TOMOSYNTHESIS
Mathematically generated 2D views (S-View)	SAMPLED	TOMOSYNTHESIS
Tomosynthesis thick reconstructed slices	SAMPLED	MAX_IP

8.1.1.35 Breast Tomosynthesis Contributing Sources

TABLE 8.1- 36 BREAST TOMOSYNTHESIS CONTRIBUTING SOURCES OF CREATED BREAST TOMOSYNTHESIS IMAGE STORAGE SOP INSTANCES

Attribute Name	Tag	Type	DICOM Attribute Description	Presence of Value	Source
Contributing Source Sequence	(0018,9506)	1	A sequence that describes characteristics of the sources that are used to create a derived SOP Instance. One or more Items shall be included in this sequence.□	ALWAYS	AUTO
>Manufacturer	(0008,0070)	2	Manufacturer of the equipment that produced the sources.	ALWAYS Value is "FUJIFILM Corporation"	AUTO
>Manufacturer's Model Name	(0008,1090)	1C	Manufacturer's model name of the equipment that produced the sources. Required if present and consistent in the contributing SOP Instances.	ALWAYS Value is "FDR-3000AWS"	AUTO
>Device Serial Number	(0018,1000)	1C	Manufacturer's serial number of the equipment that produced the sources. Required if present and consistent in the contributing SOP Instances.	ANAP	CONFIG
>Software Version	(0018,1020)	1C	Manufacturer's designation of software version of the equipment that produced PS 3.3 - 2011 Page 106 - Standard - the sources.	ALWAYS	AUTO
>Acquisition DateTime	(0008,002A)	1C	The time the acquisition of data that resulted in sources started. The value shall be the start date and time of the first contributing SOP Instance of the group specified by the Contributing SOP Instances Reference Sequence (0020,9529). Required if present and consistent in the contributing SOP Instances.	ALWAYS	AUTO

Attribute Name	Tag	Type	DICOM Attribute Description	Presence of Value	Source
>Station Name	(0008,1010)	1C	User defined name identifying the machine that produced the sources. Required if present and consistent in the contributing SOP Instances.	ALWAYS	CONFIG
>Operator's Name	(0008,1070)	1C	Name(s) of the operator(s) supporting the Series. Required if present and consistent in the contributing SOP Instances.	ALWAYS	USER
>Protocol Name	(0018,1030)	1C	User-defined description of the conditions under which the Series was performed. Required if present and consistent in the contributing SOP Instances.	ALWAYS	CONFIG
>Performed Protocol Code Sequence	(0040,0260)	1C	Sequence describing the Protocol performed for the Procedure Step creating the sources. One or more Items shall be included in this Sequence. Required if present and consistent in the contributing SOP Instances.	ANAP	MWL
>>Code Value	(0008,0100)	1	Required if a sequence item is present.	ALWAYS	MWL
>>Coding Scheme >>Designator	(0008,0102)	1	Required if a sequence item is present.	ALWAYS	MWL
>>Code Meaning	(0008,0104)	1	Required if a sequence item is present.	ALWAYS	MWL
>Rows	(0028,0010)	1	Number of rows in the images.	ALWAYS	AUTO
>Columns	(0028,0011)	1	Number of columns in the images.	ALWAYS	AUTO
>Bits Stored	(0028,0101)	1	Number of bits stored for each pixel sample. Each sample shall have the same number of bits stored.	ALWAYS	AUTO

Attribute Name	Tag	Type	DICOM Attribute Description	Presence of Value	Source
>Lossy Image Compression	(0028,2110)	1C	Specifies whether the Source Images have undergone lossy compression. Enumerated Values: 00 = Image has NOT been subjected to lossy compression. 01 = Image has been subjected to lossy compression.	ANAP If present, Value is "00"	AUTO
>Detector Type	(0018,7004)	1	The type of detector used to acquire this image.	ALWAYS Value is "STORAGE"	AUTO
>Detector ID	(0018,700A)	1	The ID or serial number of the detector used to acquire this image.□	ALWAYS	CONFIG /AUTO
>Date of Last Detector Calibration	(0018,700C)	1	The date on which the detector used to acquire this image as identified in Detector ID (0018,700A) was last calibrated.	ALWAYS	AUTO
>Time of Last Detector Calibration	(0018,700E)	1	The time at which the detector used to acquire this image as identified in Detector ID (0018,700A) was last calibrated.□	ALWAYS	AUTO
>Detector Element Spacing	(0018,7022)	1	Physical distance between the center of each detector element, specified by a numeric pair: row spacing value (delimiter) column spacing value in mm.	ALWAYS	AUTO

8.1.1.36 Breast Tomosynthesis Acquisition

TABLE 8.1- 37 BREAST TOMOSYNTHESIS ACQUISITION OF CREATED BREAST TOMOSYNTHESIS IMAGE STORAGE SOP INSTANCES

Attribute Name	Tag	Type	DICOM Attribute Description	Presence of Value	Source
X-Ray 3D Acquisition Sequence	(0018,9507)	1	Each Item represents an acquisition context related to one or more reconstructions. The values of Acquisition Index (0020,9518) may be used as index in this sequence. One or more Items shall be included in this sequence.□	ALWAYS	AUTO
>Field Of View Shape	(0018,1147)	1	Shape of the Field of View in the source projection images. Enumerated Values: RECTANGLE□	ALWAYS	AUTO
>Field of View Dimension(s) in Float	(0018,9461)	1C	Dimensions in mm of the Field of View in the source projection images. If Field of View Shape (0018,1147) is: RECTANGLE: row dimension followed by column. ROUND: diameter. HEXAGONAL: diameter of the circle circumscribing the hexagon. Required if present and consistent in the contributing SOP Instances. Required if Modality (0008,0060) is MG.	ANAP	AUTO
>Grid	(0018,1166)	1C	Identifies the grid. May be multi-valued. See Attribute Description in Section C.8.7.11 for Defined Terms. Required if present and consistent in the contributing SOP Instances. Required if Modality (0008,0060) is MG.	ANAP	AUTO
>KVP	(0018,0060)	1C	Average of the peak kilo voltage outputs of the X-Ray generator used for all frames. Required if present and consistent in the contributing SOP Instances. Required if Modality (0008,0060) is MG.	ANAP	AUTO

Attribute Name	Tag	Type	DICOM Attribute Description	Presence of Value	Source
>X-Ray Tube Current in mA	(0018,9330)	1C	Average of the nominal X-Ray tube currents in milliamperes for all frames. Required if present and consistent in the contributing SOP Instances. Required if Modality (0008,0060) is MG.	ANAP	AUTO
>Exposure Time in ms	(0018,9328)	1C	Total (cumulative) duration of X-Ray exposure for all frames in milliseconds. See Section C.8.7.2.1.1. Required if present and consistent in the contributing SOP Instances. Required if Modality (0008,0060) is MG.	ANAP	AUTO
>Exposure in mAs	(0018,9332)	1C	The total (cumulative) exposure for all frames expressed in milliampereseconds, for example calculated from Exposure Time and X-Ray Tube Current. Required if present and consistent in the contributing SOP Instances. Required if Modality (0008,0060) is MG.	ANAP	AUTO
>Primary Positioner Scan Arc	(0018,9508)	1C	Total amount of rotation of the primary positioner in degrees. Required if present and consistent in the contributing SOP Instances. Required if Modality (0008,0060) is MG.	ANAP	AUTO
>Primary Positioner Scan Start Angle	(0018,9510)	1C	Start position of the primary positioner in degrees. See Section C.8.7.5.1.2 or Section C.8.11.7, depending on modality and positioner type. Required if present and consistent in the contributing SOP Instances. Required if Modality (0008,0060) is MG.	ANAP	AUTO
>Primary Positioner Increment	(0018,9514)	1C	Constant increment of the primary positioner angle in degrees. Positive increment indicates an increasing value of the primary positioner angle.	ANAP	AUTO

Attribute Name	Tag	Type	DICOM Attribute Description	Presence of Value	Source
>Distance Source to Detector	(0018,1110)	1	Distance in mm from source to detector center on the chest wall line.	ALWAYS	AUTO
>Distance Source to Patient	(0018,1111)	1	Distance in mm from source to the bucky side that is closest to the Imaging Subject, as measured along the X-Ray beam vector.	ALWAYS	AUTO
>Estimated Radiographic Magnification Factor	(0018,1114)	1	Ratio of Source Image Receptor Distance (SID) over Source Object Distance (SOD).	ALWAYS	AUTO
>Anode Target Material	(0018,1191)	1	The primary material in the anode of the X-Ray source. Defined Terms: TUNGSTEN MOLYBDENUM RHODIUM	ALWAYS	AUTO
>Body Part Thickness	(0018,11A0)	1	The average thickness in mm of the body part examined when compressed, if compression has been applied during exposure.	ALWAYS	AUTO
>Paddle Description	(0018,11A4)	1	Description of the compression paddle, if compression was applied to the body part during exposure.	ALWAYS	AUTO
>Exposure Control Mode	(0018,7060)	1	Type of exposure control. Defined Terms: MANUAL AUTOMATIC	ALWAYS	AUTO
>Exposure Control Mode Description	(0018,7062)	1	Text description of the mechanism of exposure control. May describe the number and type of exposure sensors or position of the sensitive area of the imaging detector.	ALWAYS	AUTO
>Half Value Layer	(0040,0314)	1	The thickness of Aluminum in mm required to reduce the X-Ray Output (0040,0312) by a factor of two.	ALWAYS	AUTO

Attribute Name	Tag	Type	DICOM Attribute Description	Presence of Value	Source
>Focal Spot	(0018,1190)	1	Nominal focal spot size in mm used to acquire the projection images.	ALWAYS	AUTO
>Detector Binning	(0018,701A)	1C	Number of active detectors used to generate a single pixel. Specified as number of row detectors per pixel then column. Required if detector binning was applied to the projection images.	ANAP	AUTO
>Detector Temperature	(0018,7001)	1	Detector temperature during exposure in degrees Celsius.	ALWAYS	AUTO
>Filter Type	(0018,1160)	1	Type of filter(s) inserted into the X-Ray beam (e.g. wedges).	ALWAYS	AUTO
>Filter Material	(0018,7050)	1	The X-Ray absorbing material used in the filter. May be multi-valued.	ALWAYS	AUTO
>Per Projection Acquisition Sequence	(0018,9538)	1	Sequence containing detailed acquisition context of each individual projection used in this acquisition context.	ALWAYS	AUTO
>>KVP	(0018,0060)	1C	Exact peak kilo voltage output of the XRay generator used for this projection. Required if present and consistent in the contributing SOP Instances. Required if Modality (0008,0060) is MG.	ANAP	AUTO
>>X-Ray Tube Current in mA	(0018,9330)	1C	Exact Nominal X-Ray tube current in milliamperes applied during the Frame Acquisition Duration (0018,9220) for this projection. Required if present and consistent in the contributing SOP Instances. Required if Modality (0008,0060) is MG.	ANAP	AUTO
>>Frame Acquisition Duration	(0018,9220)	1C	The actual amount of time [in milliseconds] that was used to acquire data for this projection. .	ANAP	AUTO

Attribute Name	Tag	Type	DICOM Attribute Description	Presence of Value	Source
>>Positioner Primary Angle	(0018,1510)	1	Position in degrees of the X-Ray beam vector in the coronal anatomical plane as if the patient were standing where movement of the X-Ray source from right to vertical is positive, and vertical is zero.	ALWAYS	AUTO
>>Exposure Time in ms	(0018,9328)	1	Duration of X-Ray exposure in milliseconds.	ALWAYS	AUTO
>>Exposure in mAs	(0018,9332)	1	The exposure expressed in milliampereseconds, for example calculated from Exposure Time and XRay Tube Current.	ALWAYS	AUTO
>>Relative X-Ray Exposure	(0018,1405)	1	Indication of the applied dose, in manufacturer specific units.	ALWAYS Note: This Value is defined as Sensitivity.	AUTO
>>Organ Dose	(0040,0316)	3	Average organ dose value measured in dGy.	ALWAYS	AUTO
>>Entrance Dose in mGy	(0040,8302)	3	Average entrance dose value measured in mGy at the surface of the patient during the acquisition of this projection image.	ALWAYS	AUTO

8.1.1.37 X-Ray 3D Reconstruction

TABLE 8.1- 38 X-RAY 3D RECONSTRUCTION OF CREATED BREAST TOMOSYNTHESIS IMAGE STORAGE SOP INSTANCES

Attribute Name	Tag	Type	DICOM Attribute Description	Presence of Value	Source
X-Ray 3D Reconstruction Sequence	(0018,9530)	1	A sequence of Items each describing the characteristics of one 3D reconstruction included in this SOP instance. One or more Items shall be included in this sequence.	ALWAYS	AUTO
>Reconstruction Description	(0018,9531)	3	Free text description of the purpose of the reconstruction	ALWAYS Value is Tomo Reconstruction Algorithm Id (0019,xx4A)	AUTO
>Application Name	(0018,9524)	1	Name of the application that created the reconstruction	ALWAYS	AUTO
>Application Version	(0018,9525)	1	Version of the application that created the reconstruction.	ALWAYS	AUTO
>Application Manufacturer	(0018,9526)	1	Name of the manufacturer of the application that created the reconstruction.	ALWAYS Value is "FUJIFILM Corporation"	AUTO
>Algorithm Type	(0018,9527)	1	Type of algorithm used to create the reconstruction.	ALWAYS Value is "FILTER_BACK_PROJ"	AUTO
>Acquisition Index	(0020,9518)	1	The Item number(s) of the X-Ray 3D Acquisition Sequence (0018,9507) that describes the acquisition context(s) contributing to this reconstruction.	ALWAYS Value is "1" Fixed.	AUTO

8.1.1.38 Breast View Module

TABLE 8.1- 39 BREAST VIEW MODULE OF CREATED BREAST TOMOSYNTHESIS IMAGE STORAGE SOP INSTANCES

Attribute Name	Tag	Type	DICOM Attribute Description	Presence of Value	Source
View Code Sequence	(0054,0220)	1	Sequence that describes the view of the patient anatomy in this image. Only a single Item shall be included in this sequence.	ALWAYS	AUTO
>Code Value	(0008,0100)	1C	Required if a sequence item is present.	ALWAYS	AUTO
>Coding Scheme Designator	(0008,0102)	1C	Required if a sequence item is present.	ALWAYS	AUTO
>Coding Scheme Version	(0008,0103)	1C	Required if a sequence item is present. Required if the value of Coding Scheme Designator (0008,0102) is not sufficient to identify the Code Value (0008,0100) unambiguously.	ANAP	AUTO
>Code Meaning	(0008,0104)	1C	Required if a sequence item is present.	ALWAYS	AUTO
>View Modifier Code Sequence	(0054,0222)	2	Sequence that provides modifiers for the view of the patient anatomy. Zero or more Items shall be included in this sequence.	VNAP See DICOM PS 3.16 -2011 Page 492.	AUTO
>>Code Value	(0008,0100)	1C	Required if a sequence item is present.	ANAP	AUTO
>>Coding Scheme Designator	(0008,0102)	1C	Required if a sequence item is present.	ANAP	AUTO
>>Coding Scheme Version	(0008,0103)	1C	Required if a sequence item is present. Required if the value of Coding Scheme Designator (0008,0102) is not sufficient to identify the Code Value (0008,0100) unambiguously.	ANAP	AUTO
>>Code Meaning	(0008,0104)	1C	Required if a sequence item is present.	ANAP	AUTO

Attribute Name	Tag	Type	DICOM Attribute Description	Presence of Value	Source
Breast Implant Present	(0028,1300)	1C	Whether or not the imaged breast contains a breast implant regardless of the visibility of a breast implant in the Pixel Data. Enumerated Values: YES NO Required if Modality (0008,0060) is MG. May be present otherwise. Note: The value is expected to be YES for all images acquired on a breast that contains a breast implant, even when a breast implant is displaced during image acquisition	ANAP	AUTO
Partial View	(0028,1350)	3	Indicates whether this image is a partial view, that is a subset of a single view of the breast. Enumerated Values: YES, NO If this Attribute is absent, then the image may or may not be a partial view. Note: This may occur when a breast is larger than the active area of the detector. If this Attribute is present, its value shall be NO if there is a View Modifier Code Sequence (0054,0222) Item of value (R-102D6, SRT, "Magnification") or (R-102D7, SRT, "Spot Compression").	ALWAYS Value is "NO".	AUTO

8.1.1.39 SOP Common Module

TABLE 8.1- 40 SOP COMMON MODULE OF CREATED SOP INSTANCES

Attribute Name	Tag	Type	DICOM Attribute Description	Presence of Value	Source
SOP Class UID	(0008,0016)	1	Uniquely identifies the SOP Class. See PS3.3 C.12.1.1.1 for further explanation. See also PS 3.4.	ALWAYS	AUTO
SOP Instance UID	(0008,0018)	1	Uniquely identifies the SOP Instance. See PS3.3 C.12.1.1.1 for further explanation. See also PS 3.4.	ALWAYS	AUTO
Specific Character Set	(0008,0005)	1C	Character Set that expands or replaces the Basic Graphic Set. Required if an expanded or replacement character set is used. See PS3.3 C.12.1.1.2 for Defined Terms.	ANAP European languages: ISO_IR 100 \ ISO_IR 101 Alphanumerics: No Tag Japanese (Backslash is half-size): Half-size kana only: ISO_IR 13 Half-size kana + kanji: ISO 2022 IR 13 \ ISO 2022 IR 87 Unicode (UTF-8): ISO_IR 192 Chinese Simplified: GB18030 Korean(EUC-KR): ISO_IR 149	CONFIG

8.1.1.40 Key Object Document Module

TABLE 8.1- 41 KEY OBJECT DOCUMENT MODULE OF CREATED SOP INSTANCES

Attribute Name	Tag	Type	DICOM Attribute Description	Presence of Value	Source
Instance Number	(0020,0013)	1	A number that identifies the Document.	ALWAYS	AUTO
Content Date	(0008,0023)	1	The date the document content creation started.	ALWAYS	AUTO
Content Time	(0008,0033)	1	The time the document content creation started.	ALWAYS	AUTO
Current Requested Procedure Evidence Sequence	(0040,A375)	1	List of all Composite SOP Instances referenced in the Content Sequence (0040,A730) , including all presentation states, real world value maps and other accompanying composite instances that are referenced from the content items. One or more Items shall be included in this sequence.	ALWAYS	AUTO
>Study Instance UID	(0020,000D)	1	Unique identifier for the Study	ALWAYS	AUTO
>Referenced Series Sequence	(0008,1115)	1	Sequence of Items where each Item includes the Attributes of a Series containing referenced Composite Object(s). One or more Items may be included in this sequence	ALWAYS	AUTO
>>Series Instance UID	(0020,000E)	1	Unique identifier of a Series that is part of this Study and contains the referenced Composite Object(s).	ALWAYS	AUTO
>>Referenced SOP Sequence	(0008,1199)	1	References to Composite Object SOP Class/SOP Instance pairs that are part of the Study defined by Study Instance UID and the Series defined by Series Instance UID (0020,000E). One or more Items may be included in this sequence	ALWAYS	AUTO
>>>Referenced SOP Class UID	(0008,1150)	1	Uniquely identifies the referenced SOP Class.	ALWAYS	AUTO
>>>Referenced SOP Instance UID	(0008,1155)	1	Uniquely identifies the referenced SOP Instance.	ALWAYS	AUTO

8.1.1.41 Key Object Document Series Module

TABLE 8.1- 42 KEY OBJECT DOCUMENT SERIES MODULE OF CREATED SOP INSTANCES

Attribute Name	Tag	Type	DICOM Attribute Description	Presence of Value	Source
Modality	(0008,0060)	1	Modality type. Enumerated Value: KO = Key Object Selection	ALWAYS Value is "KO"	AUTO
Series Instance UID	(0020,000E)	1	Unique identifier of the Series.	ALWAYS	AUTO
Series Number	(0020,0011)	1	A number that identifies the Series.	ALWAYS	AUTO
Referenced Performed Procedure Step Sequence	(0008,1111)	2	Uniquely identifies the Performed Procedure Step SOP Instance for which the Series is created. Zero or one item shall be present in the sequence.	VNAP	AUTO
>Referenced SOP Class UID	(0008,1150)	1	Uniquely identifies the referenced SOP Class.	ANAP	AUTO
>Referenced SOP Instance UID	(0008,1155)	1	Uniquely identifies the referenced SOP Instance.	ANAP	AUTO

8.1.1.42 SR Document Content Module

TABLE 8.1- 43 SR DOCUMENT CONTENT MODULE OF CREATED SOP INSTANCES

Attribute Name	Tag	Type	DICOM Attribute Description	Presence of Value	Source
Include Document Content Macro TABLE 8.1-44 with a Value Type (0040,A040) of CONTAINER					
Include Document Relationship Macro TABLE 8.1-45.					

TABLE 8.1- 44 DOCUMENT CONTENT MACRO ATTRIBUTES

Attribute Name	Tag	Type	DICOM Attribute Description	Presence of Value	Source
Value Type	(0040,A040)	1	The type of the value encoded in this Content Item.	ALWAYS Defined terms: "TEXT" "NUM" "CODE" "DATETIME" "UIDREF" "IMAGE" "CONTAINER"	AUTO
Concept Name Code Sequence	(0040,A043)	1C	Code describing the concept represented by this Content Item. Also conveys the value of Document Title and section headings in documents. Only a single Item shall be permitted in this sequence. Required if Value Type (0040,A040) is TEXT, NUM, CODE, DATETIME, DATE, TIME, UIDREF or PNAME. Required if Value Type (0040,A040) is CONTAINER and a heading is present, or this is the Root Content Item. Required if Value Type (0040,A040) is COMPOSITE, IMAGE, WAVEFORM, SCOOD, SCOOD3D or TCOORD, and the Purpose of Reference is conveyed in the Concept Name.	ALWAYS	AUTO
Text Value	(0040,A160)	1C	This is the value of the Content Item. Required if Value Type (0040,A040) is TEXT. Text data which is unformatted and whose	ANAP	AUTO

Attribute Name	Tag	Type	DICOM Attribute Description	Presence of Value	Source
			<p>manner of display is implementation dependent.</p> <p>The text value may contain spaces, as well as multiple lines separated by either LF, CR, CR LF or LF CR, but otherwise no format control characters (such as horizontal or vertical tab and form feed) shall be present, even if permitted by the Value Representation of UT. The text shall be interpreted as specified by Specific Character Set (0008,0005) if present in the SOP Common Module.</p> <p>Note: The text may contain single or multibyte characters and use code extension techniques as described in PS 3.5 if permitted by the values of Specific Character Set (0008,0005).</p>		
DateTime	(0040,A120)	1C	This is the value of the Content Item. Required if Value Type (0040,A040) is DATETIME.	ANAP	AUTO
UID	(0040,A124)	1C	This is the value of the Content Item. Required if Value Type (0040,A040) is UIDREF.	ANAP	AUTO
Include 'Numeric Measurement Macro' TABLE 8.1-46 if and only if Value Type (0040,A040) is NUM.					
Include 'Code Macro' TABLE 8.1-47 if and only if Value Type (0040,A040) is CODE.					
Include 'Image Reference Macro' TABLE 8.1-48 if and only if Value Type (0040,A040) is IMAGE.					
Include 'Container Macro' TABLE 8.1-49 if and only if Value Type (0040,A040) is CONTAINER.					

TABLE 8.1- 45 DOCUMENT RELATIONSHIP MACRO ATTRIBUTES

Attribute Name	Tag	Type	DICOM Attribute Description	Presence of Value	Source
Observation DateTime	(0040,A032)	1C	The date and time on which this Content Item was completed. For the purpose of recording measurements or logging events, completion time is defined as the time of data acquisition of the measurement, or the time of occurrence of the event. Required if the date and time are different from the Content Date (0008,0023) and Content Time (0008,0033) or the Observation DateTime (0040,A032) defined in higher items. May be present otherwise. Note: When Content Items are copied into successor reports, the Content Date (0008,0023) and Content Time (0008,0033) of the new report are likely to be different than the date and time of the original observation. Therefore this attribute may need to be included in any copied Content Items to satisfy the condition.	ALWAYS	AUTO
Content Sequence	(0040,A010)	1C	A potentially recursively nested Sequence of Items that conveys content that is the Target of Relationships with the enclosing Source Content Item. One or more Items shall be included in this sequence. Required if the enclosing Content Item has relationships. Notes: 1. If this Attribute is not present then the enclosing Item is a leaf. 2. The order of Items within this Sequence is semantically significant for presentation.	ALWAYS	AUTO
>Relationship	(0040,A010)	1	The type of relationship between the	ALWAYS	AUTO

Attribute Name	Tag	Type	DICOM Attribute Description	Presence of Value	Source
Type			(enclosing) Source Content Item and the Target Content Item. IODs specify additional constraints on Relationships (including lists of Enumerated Values). Defined Terms: CONTAINS HAS PROPERTIES HAS OBS CONTEXT HAS ACQ CONTEXT INFERRED FROM SELECTED FROM HAS CONCEPT MOD	VALUE is "HAS CONCEPT MOD" or "CONTAINS"	
>Include Document Relationship Macro TABLE 8.1-45 if the Target Content Item is included by-value in the Source Content Item. The Macro shall not be present if the relationship is by-reference.					
>Include Document Content Macro TABLE 8.1-44 if the Target Content Item is included by-value in the Source Content Item. The Macro shall not be present if the relationship is by-reference.					

TABLE 8.1- 46 NUMERIC MESUREMENT MACRO ATTRIBUTES

Attribute Name	Tag	Type	DICOM Attribute Description	Presence of Value	Source
Measured Value Sequence	(0040,A300)	2	This is the value of the Content Item. Shall consist of a Sequence of Items conveying the measured value(s), which represent integers or real numbers and units of measurement. Zero or one Item shall be included in this sequence.	ALWAYS	AUTO
>Numeric Value	(0040,A30A)	1	Numeric measurement value. Only a single value shall be present.	ALWAYS	AUTO
>Measurement Units Code Sequence	(0040,08EA)	1	Units of measurement. Only a single Item shall be included in this sequence.	ALWAYS	AUTO
>>Code Value	(0008,0100)	1	Required if a sequence item is present.	ALWAYS	AUTO
>>Coding Scheme Designator	(0008,0102)	1	Required if a sequence item is present.	ALWAYS	AUTO
>>Coding Scheme Version	(0008,0103)	1C	Required if a sequence item is present. Required if the value of Coding Scheme Designator (0008,0102) is not sufficient to identify the Code Value (0008,0100) unambiguously.	ALWAYS	AUTO

Attribute Name	Tag	Type	DICOM Attribute Description	Presence of Value	Source
>> Code Meaning	(0008,0104)	1	Required if a sequence item is present.	ALWAYS	AUTO

TABLE 8.1- 47 CODE MACRO ATTRIBUTES

Attribute Name	Tag	Type	DICOM Attribute Description	Presence of Value	Source
Concept Code Sequence	(0040,A168)	1	This is the value of the Content Item. Only a single Item shall be included in this sequence.	ALWAYS	AUTO/USER
>Code Value	(0008,0100)	1	Required if a sequence item is present.	ALWAYS	AUTO
>Coding Scheme Designator	(0008,0102)	1	Required if a sequence item is present.	ALWAYS	AUTO
>Coding Scheme Version	(0008,0103)	1C	Required if a sequence item is present. Required if the value of Coding Scheme Designator (0008,0102) is not sufficient to identify the Code Value (0008,0100) unambiguously.	ALWAYS	AUTO
> Code Meaning	(0008,0104)	1	Required if a sequence item is present.	ALWAYS	AUTO

TABLE 8.1- 48 IMAGE REFERENCE MACRO ATTRIBUTES

Attribute Name	Tag	Type	DICOM Attribute Description	Presence of Value	Source
Referenced SOP Sequence	(0008,1199)	1	References to Composite Object SOP Class/SOP Instance pairs. Only a single Item shall be included in this Sequence.	ALWAYS	AUTO
>Referenced SOP Class UID	(0008,1150)	1	Uniquely identifies the referenced SOP Class.	ANAP	AUTO
>Referenced SOP Instance UID	(0008,1155)	1	Uniquely identifies the referenced SOP Instance.	ANAP	AUTO

TABLE 8.1- 49 CONTAINER MACRO ATTRIBUTES

Attribute Name	Tag	Type	DICOM Attribute Description	Presence of Value	Source
Continuity of	(0040,A050)	1	This flag specifies for a CONTAINER whether or not	ALWAYS	AUTO

Attribute Name	Tag	Type	DICOM Attribute Description	Presence of Value	Source
Content			its contained Content Items are logically linked in a continuous textual flow, or are separate items. Enumerated Values: SEPARATE CONTINUOUS	VALUE is SEPARATE	
Content Template Sequence	(0040,A504)	1C	Template that describes the content of this Content Item and its subsidiary Content Items. Only a single Item shall be included in this sequence. Required if a template was used to define the content of this Item, and the template consists of a single CONTAINER with nested content, and it is the outermost invocation of a set of nested templates that start with the same CONTAINER	ALWAYS	AUTO
>Mapping Resource	(0008,0105)	1	Mapping Resource that defines the template. See Section 8.4. Defined Terms: DCMR = DICOM Content Mapping Resource	ALWAYS	AUTO
>Template Identifier	(0040,DB00)	1	Template identifier.	ALWAYS	AUTO

8.1.1.43 X-Ray Radiation Dose SR Module

TABLE 8.1- 50 SR DOCUMENT SERIES MODULE OF CREATED X-RAY RADIATION DOSE SR SOP INSTANCES

Attribute Name	Tag	Type	Dicom Attribute Description	Presence of Value	Source
Modality	(0008,0060)	1	Modality type. Enumerated Value: SR = SR Document	ALWAYS Value is "SR"	AUTO
Referenced Study Component Sequence	(0008,1111)	2	Uniquely identifies the Performed Procedure Step SOP Instance for which the Series is created. Zero or one item shall be present in the sequence. Notes: 1. The Performed Procedure Step referred to by this Attribute is the Step during which this Document is generated. 2. If this Document is generated during the same Modality or General Purpose Performed Procedure Step as the evidence in the current interpretation procedure, this attribute may contain reference to that Modality or General Purpose Performed Procedure Step. 3. This Attribute is not used to convey reference to the evidence in the current interpretation procedure. See Current Requested Procedure Evidence Sequence (0040,A375). 4. This Sequence may be sent zero length if the Performed Procedure Step is unknown.	EMPTY	AUTO
Series Instance UID	(0020,000E)	1	Unique identifier of the Series. Note: No SR-specific semantics are specified.	ALWAYS	AUTO
Series Number	(0020,0011)	1	A number that identifies the Series. Note: No SR-specific semantics are specified.	ALWAYS	AUTO

TABLE 8.1- 51 SR DOCUMENT GENERAL MODULE OF CREATED X-RAY RADIATION DOSE SR SOP INSTANCES

Attribute Name	Tag	Type	Dicom Attribute Description	Presence of Value	Source
Content Date	(0008,0023)	1	The date the document content creation started.	ALWAYS	AUTO
Content Time	(0008,0033)	1	The time the document content creation started.	ALWAYS	AUTO
Instance Number	(0020,0013)	1	A number that identifies the SR Document.	ALWAYS	AUTO
Performed Procedure Code Sequence	(0040,A372)	2	A Sequence that conveys the codes of the performed procedures pertaining to this SOP Instance. Zero or more Items may be included in this sequence.	EMPTY	AUTO

Attribute Name	Tag	Type	Dicom Attribute Description	Presence of Value	Source
Completion Flag	(0040,A491)	1	The estimated degree of completeness of this SR Document with respect to externally defined criteria in a manner specified in the Conformance Statement. Note: It may be desirable to make these criteria adaptable to local policies or user decisions. Enumerated Values: PARTIAL = Partial content. COMPLETE = Complete content.	ALWAYS Value is "COMPLETE"	AUTO
Verification Flag	(0040,A493)	1	Indicates whether this SR Document is Verified. Enumerated Values: UNVERIFIED = Not attested to. VERIFIED = Attested to by a Verifying Observer Name (0040,A075) who is accountable for its content. Note: The intent of this specification is that the "prevailing final version" of an SR Document is the version having the most recent Verification DateTime (0040,A030), Completion Flag (0040,A491) of COMPLETE and Verification Flag (0040,A493) of VERIFIED.	ALWAYS Value is "VERIFIED"	AUTO

8.1.2 Used Fields in received IOD by application

The AWS storage application does not receive SOP Instances.

8.1.3 Attribute mapping

The relationships between attributes received via Modality Worklist, stored in acquired images and communicated via MPPS are summarized in following table.

TABLE 8.1- 52 ATTRIBUTE MAPPING BETWEEN MODALITY WORKLIST, IMAGE AND MPPS

Modality Worklist	Image IOD	MPPS IOD
Specific Character Set	Specific Character Set	Specific Character Set
-	-	Scheduled Step Attribute Sequence
Study Instance UID	Study Instance UID	>Study Instance UID
Referenced Study Sequence	>Referenced Study Sequence	>Referenced Study Sequence
>Referenced SOP Class UID	>>Referenced SOP Class UID	>>Referenced SOP Class UID
>Referenced SOP Instance UID	>>Referenced SOP Instance UID	>>Referenced SOP Instance UID
Accession Number	Accession Number	>Accession Number
Requested Procedure ID	Requested Procedure ID	>Requested Procedure ID
Requested Procedure Description	-	>Requested Procedure Description
>Scheduled Procedure Step ID	>Scheduled Procedure Step ID	>Scheduled Procedure Step ID
>Scheduled Procedure Step Description	>Scheduled Procedure Step Description	>Scheduled Procedure Step Description
>Scheduled Protocol Code Sequence	>Scheduled Protocol Code Sequence	>Scheduled Protocol Code Sequence
>>Code Value	>>Code Value	>>Code Value
>>Coding Scheme Designator	>>Coding Scheme Designator	>>Coding Scheme Designator

Modality Worklist	Image IOD	MPPS IOD
>>Coding Scheme Version	>>Coding Scheme Version	>>Coding Scheme Version
>>Code Meaning	>>Code Meaning	>>Code Meaning
Patient's Name	Patient's Name	Patient's Name
Patient ID	Patient ID	Patient ID
Patient's Birth Data	Patient's Birth Data	Patient's Birth Data
Patient's Sex	Patient's Sex	Patient's Sex
Referenced Patient Sequence	-	Referenced Patient Sequence
>Referenced SOP Class UID	-	>Referenced SOP Class UID
>Referenced Instance UID	-	>Referenced Instance UID
Modality	Modality	Modality
Requested Procedure ID	Study ID	Study ID
>Scheduled Protocol Code Sequence	Performed Protocol Code Sequence	Performed Protocol Code Sequence
>>Code Value	>Code Value	>Code Value
>>Coding Scheme Designator	>Coding Scheme Designator	>Coding Scheme Designator
>>Coding Scheme Version	>Coding Scheme Version	>Coding Scheme Version
>>Code Meaning	>Code Meaning	>Code Meaning

8.1.4 Coerced/Modified Fields

Not applicable.

8.1.5 STRUCTURED REPORT DOCUMENT INFORMATIONS

8.1.5.1 Key Object Selection

8.1.5.1.1 Template Structure

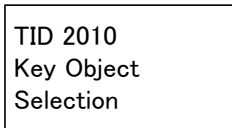

TID2010 Key Object Selection Structure

TABLE 8.1- 53 KEY OBJECT SELECTION STRUCTURE

NL	Rel with Parent	VT	Concept Name	VM	Presence of Value	Value Set Constraint
		CONTAINER	DCID(7010) Key Object Selection Document Titles	1	ALWAYS	DT (113001, DCM, "Rejected for Quality Reason") or DT (103037, DCM, "Rejected for Patient Safety Reasons") or DT (113000, DCM, "Of Interest") or DT (113010, DCM, "Quality Issue")

NL	Rel with Parent	VT	Concept Name	VM	Presence of Value	Value Set Constraint
>	HAS CONCEPT MOD	CODE	EV (113011, DCM, "Document Title Modifier")	1-n	ALWAYS IFF Row 1 value = (113001, DCM, "Rejecte d for Quality Reason") or (103037, DCM, "Rejecte d for Patient Safety Reasons") or (113010, DCM, " Quality Issue")	
>	CONTAINS	IMAGE	Purpose of Reference shall not be present	1-n	ALWAYS	

8.1.5.2 X-Ray Radiation Dose Report

8.1.5.2.1 Template Structure

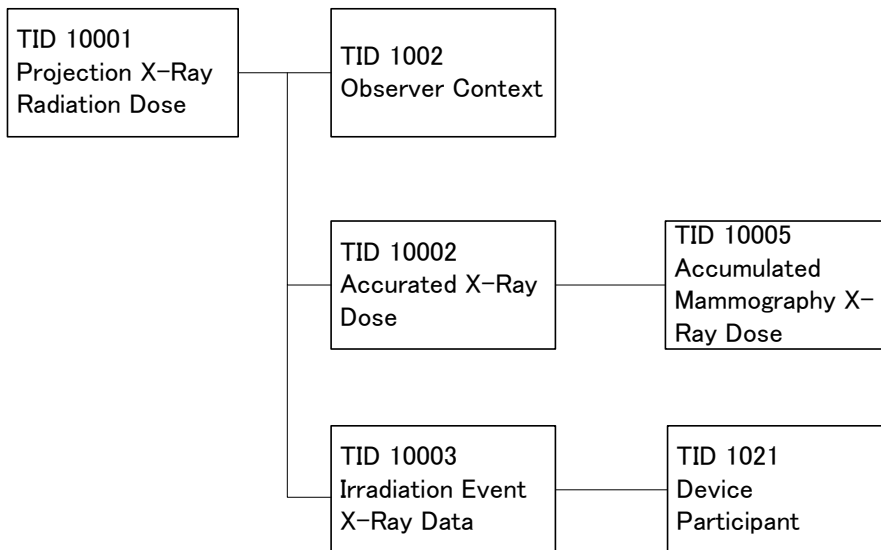

8.1.5.2.2 TID1001 Projection X-Ray Radiation Dose Structure

TABLE 8.1- 54 PROJECTION X-RAY RADIATION DOSE STRUCTURE

NL	Rel with Parent	VT	Concept Name	VM	Presence of Value	Value Set Constraint
		CONTAINER	EV (113701, DCM, "X-Ray Radiation Dose Report")	1	ALWAYS	
>	HAS CONCEPT MOD	CODE	EV (121058, DCM, "Procedure reported")	1	ALWAYS	DT (P5-40010, SRT, "Mammography")
>>	HAS CONCEPT MOD	CODE	EV (G-C0E8, SRT, "Has Intent")	1	ALWAYS	DT (R-408C3, SRT, "Diagnostic Intent")
>		INCLUDE	DTID (1002) Observer Context	1-n	ALWAYS	
>	CONTAINS	INCLUDE	DTID (10002) Accumulated X-Ray Dose	1	ALWAYS	
>	CONTAINS	INCLUDE	DTID (10003) Irradiation Event X-Ray Data	1-n	ALWAYS	
>	CONTAINS	CODE	EV (113854, DCM, "Source of Dose Information")	1-n	ALWAYS	DCID (10020) Source of Projection X-Ray Dose Information "Automated Data Collection"

8.1.5.2.3 TID1002 Observer Context Structure

TABLE 8.1- 55 OBSERVER CONTEXT STRUCTURE

NL	Rel with Parent	VT	Concept Name	VM	Presence of Value	Value Set Constraint
	HAS OBS CONTEXT	CODE	EV (121005, DCM, "Observer Type")	1	ALWAYS	DCID (270) Observer Type Defaults to (121006, DCM, "Person")

8.1.5.2.4 TID10002 Accumulated X-Ray Dose Data Structure

TABLE 8.1- 56 ACCUMULATED X-RAY DOSE DATA STRUCTURE

NL	Rel with Parent	VT	Concept Name	VM	Presence of Value	Value Set Constraint
		CONTAINER	EV (113702, DCM, "Accumulated X-Ray Dose Data")	1	ALWAYS	
>	HAS CONCEPT MOD	CODE	EV (113764, DCM, "Acquisition Plane")	1	ALWAYS	DT (163622, DCM, "Single Plane")
>	CONTAINS	INCLUDE	DTID (10005) Accumulated Mammography XRay Dose	1	ALWAYS	

8.1.5.2.5 TID10005 Accumulated Mammography X-Ray Dose Data Structure

TABLE 8.1- 57 ACCUMULATED MAMMOGRAPHY X-RAY DOSE DATA STRUCTURE

NL	Rel with Parent	VT	Concept Name	VM	Presence of Value	Value Set Constraint
		NUM	EV (111637, DCM, "Accumulated Average Glandular Dose")	1-2	ALWAYS	Units = EV (dGy, UCUM, "dGy")
>	HAS CONCEPT MOD	CODE	EV (G-C171, SRT, "Laterality")	1	ALWAYS	DCID (6022) Side

8.1.5.2.6 TID10003 Irradiation Event X-Ray Data

TABLE 8.1- 58 IRRADIATION EVENT X-RAY DATA

NL	Rel with Parent	VT	Concept Name	VM	Presence of Value	Value Set Constraint
		CONTAINER	EV (113706, DCM, "Irradiation Event X-Ray Data")	1	ALWAYS	
>	HAS CONCEPT MOD	CODE	EV (113764, DCM, "Acquisition Plane")	1	ALWAYS	DCID (10003) Equipment Plane Identification "Single Plane"
>	CONTAINS	DATETIME	DT (111526, DCM, "DateTime Started")	1	ALWAYS	

NL	Rel with Parent	VT	Concept Name	VM	Presence of Value	Value Set Constraint
>	CONTAINS	CODE	EV (113721, DCM, "Irradiation Event Type")	1	ALWAYS	DCID (10002) Irradiation Event Types "Stationary Acquisition"
>	CONTAINS	UIDREF	EV (113769, DCM, "Irradiation Event UID")	1	ALWAYS	
>	CONTAINS	NUM	EV (111631, DCM, "Average Glandular Dose")	1	ALWAYS IFF TID (10001) Row 2 = (P5-40010, SRT, "Mammography")	Units = EV (dGy, UCUM, "dGy")
>	CONTAINS	NUM	EV (111636, DCM, "Entrance Exposure at RP")	1	ALWAYS IFF TID (10001) Row 2 = (P5-40010, SRT, "Mammography")	Units = EV (mGy, UCUM, "mGy")
>	CONTAINS	NUM	EV (112011, DCM, "Positioner Primary Angle")	1	ANAP XOR Row 19	Units = EV (deg, UCUM, "deg")
>	CONTAINS	NUM	EV (113733, DCM, "KVP")	1-n	ANAP	Units = EV (kV, UCUM, "kV")
>	CONTAINS	NUM	EV (113734, DCM, "X-Ray Tube Current")	1-n	ANAP	Units = EV (mA, UCUM, "mA")
>	CONTAINS	NUM	EV (113735, DCM, "Exposure Time")	1	ANAP	Units = EV (ms, UCUM, "ms")
>	CONTAINS	NUM	EV (113736, DCM, "Exposure")	1-n	ANAP	Units = EV (uAs, UCUM, "uAs")
>	CONTAINS	CODE	EV (123014, DCM, ("Target Region"))	1	ALWAYS	DCID (4031) Common Anatomic Regions
>	CONTAINS	NUM	EV (111633, DCM, "Compression Thickness")	1	ANAP	Units = (mm, UCUM, "mm")
>	CONTAINS	INCLUDE	DTID (1021) Device Participant	1	ALWAYS Required if the irradiating device is not the recording device.	\$DeviceProcedureRole = EV (113859, DCM, "Irradiating Device")

NL	Rel with Parent	VT	Concept Name	VM	Presence of Value	Value Set Constraint
>	CONTAINS	IMAGE	EV (113795, DCM, "Acquired Image")	1-n	ALWAYS	IFF Image Object is created for this irradiation event

8.1.5.2.7 TID1021 Device Participant

TABLE 8.1- 59 DEVICE PARTICIPANT

NL	Rel with Parent	VT	Concept Name	VM	Presence of Value	Value Set Constraint
		CODE	EV (113876, DCM, "Device Role in Procedure")	1	ALWAYS	DT (113859, DCM, "Irradiating Device")
>	HAS PROPERTIES	TEXT	EV (113878, DCM, "Device Manufacturer")	1	ALWAYS	
>	HAS PROPERTIES	TEXT	EV (113879, DCM, "Device Model Name")	1	ALWAYS	
>	HAS PROPERTIES	TEXT	EV (113880, DCM, "Device Serial Number")	1	ALWAYS	

8.2 MEDIA STORAGE DIRECTORY IOD OBERVIEW

This section describes the Media Storage Directory IOD handled by AWS

8.2.1 Module Table

TABLE 8.2- 1 BASIC DIRECTORY IOD MODULES

Module	Reference	Usage	DICOM Description	Implementation on AWS
File-set Identification	8.2.1.1	M	File-set identification information	
Directory Information	8.2.1.2	U	<p>Directory Information followed by a Sequence of Directory Records.</p> <p>Note: The Directory Information Module is optional.</p> <p>This Directory Information Module should be present in all but primitive environments where a directory is not needed.</p> <p>In this case, only the File-set Identification Information is present.</p>	Handled as essential information.

8.2.1.1 File-set Identification Module

TABLE 8.2- 2 FILE-SET IDENTIFICATION MODULE

Attribute Name	Tag	Type	DICOM Attribute Description	Implementation on AWS
File-set ID	(0004,1130)	2	<p>User or implementation specific Identifier (up to 16 characters).</p> <p>For definition, see DICOM PS 3.10.</p> <p>The File-set ID is intended to be a short human readable label to easily (but not necessarily uniquely) identify a specific File-set to facilitate operator manipulation of the physical media on which the File-set is stored. Assignment of Value and semantics are environment specific.</p>	A date is set in the form of YYYYMMHHMMSS.
File-set Descriptor File ID	(0004,1141)	3	ID of a File (in the same File-set) used for user comments related to the File-set (e.g. a readme file).	
Specific Character Set of File-set Descriptor File	(0004,1142)	1C	<p>Character set used in the File-set Descriptor File with a File ID as specified in File-set Descriptor File ID (0004,1141).</p> <p>Required to specify the expanded or replacement character set.</p> <p>If absent, only the Basic Graphic set is used.</p> <p>See DICOM PS 3.3 C.12.1.1.2 for Defined Terms.</p>	

8.2.1.2 Directory Information Module

TABLE 8.2- 3 DIRECTORY INFORMATION MODULE

Attribute Name	Tag	Type	DICOM Attribute Description	Implementation on AWS
Offset of the First Directory Record of the Root Directory Entity	(0004,1200)	1	Offset of the first byte (of the Item Data Element) of the first Directory Record of the Root Directory Entity. This Offset is a number of bytes starting with the first byte of the File Meta Information. When the Root Directory Entity contains no Directory Record, this offset shall be set to 00000000H. Note: This offset includes the File Preamble and the DICM Prefix.	
Offset of the Last Directory Record of the Root Directory Entity	(0004,1202)	1	Offset of the first byte (of the Item Data Element) of the last Directory Record of the Root Directory Entity. This Offset is a number of bytes starting with the first byte of the File Meta Information. When the Root Directory Entity contains no Directory Record, this offset shall be set to 00000000H. Note: This offset includes the File Preamble and the DICM Prefix.	
File-set Consistency Flag	(0004,1212)	1	When set, this Flag indicates that an inconsistency within the Directory or between the Directory and the Files of the File-set may exist. Potential recovery actions are implementation specific and are beyond the scope of this Standard. Enumerated Values: 0000H: no known inconsistencies FFFFH: The FSR or FSU shall assume that inconsistencies are present.	
Directory Record Sequence	(0004,1220)	2	Sequence of zero or more repeating Items where each Item contains a Directory Record by including the Directory Elements from (0004,1400) to (0004,1511) and Record selection Keys as defined below (marked with a >). A zero length Value indicates that no Directory Records are contained in the Root Directory Entity.	

Attribute Name	Tag	Type	DICOM Attribute Description	Implementation on AWS
>Offset of the Next Directory Record	(0004,1400)	1C	<p>Offset of the first byte (of the Item Data Element) of the next Directory Record of the same Directory Entity. This Offset is an unsigned integer representing a number of bytes starting with the first byte of the File Meta-information. A zero offset shall be used to mean that there is no other Directory Record in this Directory Entity. Required if the Directory Record Sequence (0004,1220) is not zero length.</p> <p>This Offset may be used to keep an inactive Record (0004,1410) chained with the next Directory Record of the same Directory Entity.</p> <p>Note: This offset includes the File Preamble and the DICM Prefix.</p>	
>Record In-use Flag	(0004,1410)	1C	<p>This flag facilitates the deletion of referenced files.</p> <p>Enumerated Values: FFFFH = Record is in use. 0000H = Record is inactive. All attributes of an inactive Directory Record except (0004,1400) and (0004,1410) shall be ignored.</p>	
>Offset of Referenced Lower-Level Directory Entity	(0004,1420)	1C	<p>Referenced Lower-Level Directory Entity Offset of the first byte (of the Item Data Element) of the first Directory Record of the Referenced Lower Level Directory Entity.</p> <p>This Offset is a number of bytes starting with the first byte of the File Meta Information. Required if the Directory Record Sequence (0004,1220) is not zero length.</p> <p>Note: This offset includes the File Preamble and the DICM Prefix.</p>	

Attribute Name	Tag	Type	DICOM Attribute Description	Implementation on AWS
>Directory Record Type	(0004,1430)	1C	Defines a specialized type of Directory Record by reference to its position in the Media Storage Directory Information Model. Required if the Directory Record Sequence (0004,1220) is not zero length. Enumerated Values: PATIENT STUDY AGE OVERLAY MODALITY LUT VOI LUT CURVE TOPIC VISIT RESULTS INTERPRETATION STUDY COMPONENT STORED PRINT RT DOSE RT STRUCTURE SET RT PLAN RT TREAT RECORD PRESENTATION WAVEFORM SR DOCUMENT KEY OBJECT DOC PRIVATE MRDR	Sets the following enumerated values. PATIENT STUDY SERIES IMAGE
>Private Record UID	(0004,1432)	1C	Required if the Directory Record Type (0004,1430) is of Value PRIVATE.	
>Referenced File ID	(0004,1500)	1C	A Multiple Value (See DICOM PS 3.5) which represents the ordered components of the File ID containing a "referenced object" or Referenced SOP Instance. A maximum of 8 components, each from 1 to 8 characters shall be used. Note: The Referenced File ID provides the means to "locate" the File through the DICOM File Service provided by the Media Format Layer.	Determined when the Directory Record Type (0004,1430) is "IMAGE".
>MRDR Directory Record Offset	(0004,1504)	1C	Offset of the first byte (of the Item Data Element) of the Multi-Referenced File Directory Record.	
>Referenced SOP Class UID in File	(0004,1510)	1C	Unique ID for the SOP Class related to the IOD stored in the referenced File.	Determined when the Directory Record Type (0004,1430) is "IMAGE".
>Referenced SOP Instance UID in File	(0004,1511)	1C	Unique Identifier for the SOP Instance related to the IOD stored in the referenced file.	
>Referenced Transfer Syntax UID in File	(0004,1512)	1C	Transfer Syntax Unique Identifier for the Transfer Syntax used to encode the IOD stored in the referenced file.	

Attribute Name	Tag	Type	DICOM Attribute Description	Implementation on AWS
>Record Selection Keys	See 8.2.		A number of DICOM Data Elements which contain specific keys defined for each type of Directory Record (0004,1430).	See 8.2.

8.2.2 Relationship Between Directory Records

The table below shows directory record types included in the lower directory entities.

TABLE 8.2- 4 RELATIONSHIP BETWEEN DIRECTORY RECORDS

Directory Record Type	Reference	DICOM Definition	Implementation on AWS
(Root Directory Entity)	–	PATIENT, TOPIC, PRIVATE	PATIENT
PATINET		STUDY, PRIVATE	STUDY
STUDY		SERIES, VISIT, RESULTS, STUDY COMPONENT, PRIVATE	SEREIS
SERIES		IMAGE, OVERLAY MODARITY LUT, VOILUT CURVE, STORED PRINT, RT DOSE, RT STRUCTURE SET, RT PLAN, RT TREAT RECORD PRESENTATION, WAVEFORM, SR DOCUMENT, KEY OBJECT DOC, PRIVATE	IMAGE
IMAGE		PRIVATE	

8.2.2.1 Patient Directory Record Definition

TABLE 8.2- 5 PATIENT KEYS

Key	Tag	Type	Attribute Description
Specific Character Set	(0008,0005)	1C	To be set up when agglomerated extension or substitute characters are used.
Patient's Name	(0010,0010)	2	
Patient ID	(0010,0020)	1	
Patient's Birthday	(0010,0030)	3	
Patient's Sex	(0010,0040)	3	

8.2.2.2 Study Directory Record Definition

TABLE 8.2- 6 STUDY KEYS

Key	Tag	Type	Attribute Description
Specific Character Set	(0008,0005)	1C	To be set up when agglomerated extension or substitute characters are used.
Study Date	(0008,0020)	1	
Study Time	(0008,0030)	1	
Study Description	(0008,1030)	2	
Study Instance UID	(0020,000D)	1	
Study ID	(0020,0010)	1	

Key	Tag	Type	Attribute Description
Accession Number	(0008,0050)	2	
Referring Physician's Name	(0008,0090)	3	
Requesting Service	(0032,1033)	3	

8.2.2.3 Series Directory Record Definition

TABLE 8.2- 7 SERIES KEYS

Key	Tag	Type	Attribute Description
Specific Character Set	(0008,0005)	1C	To be set up when agglomerated extension or substitute characters are used.
Modality	(0008,0060)	1	
Series Instance UID	(0020,000E)	1	
Series Number	(0020,0011)	1	
Body Part Examined	(0018,0015)	3	

8.2.2.4 Image Directory Record Definition

TABLE 8.2- 8 IMAGE KEYS

Key	Tag	Type	Attribute Description
Specific Character Set	(0008,0005)	1C	To be set up when agglomerated extension or substitute characters are used.
Image Number	(0020,0013)	1	
Image Type	(0008,0008)	1C	To be set up essentially for DVD/USB memory storage. Setup needed also for other than DVD/USB memory storage.
SOP Instance UID	(0008,0018)	3	
Content Date	(0008,0023)	3	
Content Time	(0008,0033)	3	
Acquisition Device Processing Description	(0018,1400)	3	
Acquisition Device Processing Code	(0018,1401)	3	
Image ID	(0021,xx10)	3	This key is private attribute. ID of an image generated by the Fuji system, consisting of the four characters. The first one character constitutes an ID that identifies each device, and the remaining three characters constitute a serial number for an image generated by a certain device. Numbers from 000 to 999 are used cyclically.

8.3 DATA DICTIONARY OF PRIVATE ATTRIBUTES

TABLE 8.3- 1 DATA DICTIONARY OF PRIVATE ATTRIBUTES

Attribute Name	Tag	VR	VM	Notes
Irradiation Event UID	(0008,3010)	LO	1-n	(Only FDR-3000AWS)
Private Creator	(0009,00xx)	LO	1	Value is "FDMS 1.0"
Image Control Unit	(0009,xx04)	SH	1	
Image UID	(0009,xx05)	OW	1	
Route Image UID	(0009,xx06)	OW	1	
Image Display Information Version No.	(0009,xx08)	UL	1	
Patient Information Version No.	(0009,xx09)	UL	1	
Film UID	(0009,xx0C)	OW	1	
Exposure Unit Type Code	(0009,xx10)	CS	1	
Direction of Arm Positive Rotation	(0009,xx30)	CS	1	Value is "0" 0:Clockwise 1:Counter Clockwise ※ Direction of the X-ray source when patient is standing. (Only FDR-1000AWS / FDR-2000AWS / FDR-3000AWS)
Kanji Hospital Name	(0009,xx80)	LO	1	
Distribution Code	(0009,xx90)	ST	1	
Kanji Department Name	(0009,xx92)	SH	1	
Blackening Process Flag	(0009,xxF0)	CS	1	
Processing Information Flag	(0009,xxF1)	ST	1	
Normalization Flag	(0009,xxF2)	CS	1	
Tone Characteristic	(0009,xxF3)	CS	1	
Referenced Image for Stereopsis Sequence	(0009,xxF5)	SQ	1	(Only FDR-1000AWS / FDR-2000AWS / FDR-3000AWS)
>Referenced SOP Class UID	(0008,1150)	UI	1	(Only FDR-1000AWS / FDR-2000AWS / FDR-3000AWS)
>Referenced SOP Instance UID	(0008,1155)	UI	1	(Only FDR-1000AWS / FDR-2000AWS / FDR-3000AWS)
Referenced Image for TomoSet Sequence	(0009,xxF6)	SQ	1	(Only FDR-3000AWS)
>Referenced SOP Class UID	(0008,1150)	UI	1	(Only FDR-3000AWS)
>Referenced SOP Instance UID	(0008,1155)	UI	1	(Only FDR-3000AWS)
FSC Flag	(0009,xxF9)	CS	1	(Only FDR-3000AWS)
Plate ID	(0018,1004)	LO	1	
Private Creator	(0019,00xx)	LO	1	Value is "FDMS 1.0"

Attribute Name	Tag	VR	VM	Notes
Kanji Body Part for Exposure	(0019,xx15)	LO	1	
Stereo Angle	(0019,xx20)	FL	1	(Only FDR-1000AWS / FDR-2000AWS / FDR-3000AWS) See „Direction of Arm Positive Rotation“ (0009,XX30) for further explanation of direction. (degree)
Radiographic Type	(0019,xx21)	LO	1	(Only FDR-1000AWS / FDR-2000AWS / FDR-3000AWS) It sets “STEREO” when the menu is SDM menu. It sets “BIOPSY” when the menu is Biopsy menu.
Pre-exposure Result SQ	(0019,XX23)	SQ	1	(Only FDR-1000AWS / FDR-2000AWS / FDR-3000AWS) Pre-exposure result SQ. Generated when AEC is Auto/Semi.
> KVP	(0018,0060)	DS	1	
> Exposure Time	(0018,1150)	IS	1	
> X-Ray Tube Current	(0018,1151)	IS	1	
> Exposure	(0018,1152)	IS	1	
> Exposure in µAs	(0018,1153)	IS	1	
> Anode Target Material	(0018,1191)	CS	1	
> Filter Material	(0018,7050)	CS	1	
> Average Organ Dose (dGy)	(0040,0316)	DS	1	
> Entrance Dose in mGy	(0040,8302)	DS	1	
Exposure Dose Level	(0019,xx22)	CS	1-3	(Only FDR-1000AWS / FDR-2000AWS / FDR-3000AWS)
Kanji Menu Name	(0019,xx32)	LO	1	
Image Processing Type	(0019,xx40)	CS	1	
Tomo Kind Info	(0019,xx44)	CS	1	(Only FDR-3000AWS)
Tomo Slice Center Height	(0019,xx45)	DS	1	(Only FDR-3000AWS)
Tomo Slice Range	(0019,xx46)	DS	1	(Only FDR-3000AWS)
Tomo Slice Pitch	(0019,xx47)	DS	1	(Only FDR-3000AWS)
Bookmark	(0019,xx48)	CS	1	(Only FDR-3000AWS)
Tomo Mode	(0019,xx49)	CS	1	(Only FDR-3000AWS)
Tomo Reconstruction Algorithm Id	(0019,xx4A)	CS	1	(Only FDR-3000AWS)
EDR Mode	(0019,xx50)	CS	1	

Attribute Name	Tag	VR	VM	Notes
Density Category	(0019,xx55)	DS	3	(Only FDR-1000AWS / FDR-2000AWS / FDR-3000AWS)
Fibroglandular(%)	(0019,xx56)	DS	3	(Only FDR-1000AWS / FDR-2000AWS / FDR-3000AWS)
Adipose(cm3)	(0019,xx57)	DS	3	(Only FDR-1000AWS / FDR-2000AWS / FDR-3000AWS)
Fibroglandular(cm3)	(0019,xx58)	DS	3	(Only FDR-1000AWS / FDR-2000AWS / FDR-3000AWS)
Breast(cm3)	(0019,xx59)	DS	3	(Only FDR-1000AWS / FDR-2000AWS / FDR-3000AWS)
Radiographer's Code	(0019,xx60)	SH	1	
Split Exposure Format	(0019,xx70)	IS	1	
No. Of Split Exposure Frames	(0019,xx71)	IS	1	
Reading Position Specification	(0019,xx80)	IS	1	
Reading Sensitivity Center	(0019,xx81)	IS	1	
Film Annotation Character String 1	(0019,xx90)	SH	1	
Film Annotation Character String 2	(0019,xx91)	SH	1	
Private Creator	(0021,00xx)	LO	1	Value is "FDMS 1.0"
Image ID	(0021,xx10)	CS	1	
Set No.	(0021,xx30)	CS	1	
Image No. In the Set	(0021,xx40)	IS	1	
Pair Processing Information	(0021,xx50)	CS	1	
Equipment Type-Specific Information	(0021,xx80)	OB	1	
Private Creator	(0023,00xx)	LO	1	Value is "FDMS 1.0"
Single-image Processing Parameter Sequence	(0023,xx30)	SQ	1	
> Latitude	(0025,1013)	US	1	
Private Creator	(0025,00xx)	LO	1	Value is "FDMS 1.0"
Relative Light Emission Amount Sk	(0025,xx10)	US	1	
Term of Correction for Each IP Type St	(0025,xx11)	US	1	
Reading Gain Gp	(0025,xx12)	US	1	
Private Creator	(0027,00xx)	LO	1	Value is "FDMS 1.0"
Private Creator	(0029,00xx)	LO	1	Value is "FDMS 1.0"
Image Scanning Direction	(0029,xx20)	CS	1	
Extended Reading Size Value	(0029,xx30)	CS	1	
Mag./Reduc. Ratio	(0029,xx34)	US	1	
Line Density Code	(0029,xx44)	CS	1	
Data Compression Code	(0029,xx50)	CS	1	

Attribute Name	Tag	VR	VM	Notes
Breast Wall Direction	(0029,xx60)	US	1	Left : 1 Right : 2 Top : 3 Bottom : 4 ※ When Pixel Padding Value(0028,0120) is executed by using (50F1,xx0C), it is indispensable.
Acquisition Image Status	(0029,xx61)	CS	1	Value is "NORMAL", "MISS"
Requesting Physician	(0032,1032)	PN	1	
Requesting Service	(0032,1033)	LO	1	
Study Comments	(0032,4000)	LT	1	
Image Display Format	(2010,0010)	ST	1	
Annotation Display Format ID	(2010,0030)	CS	1	
Film Orientation	(2010,0040)	CS	1	
Border Density	(2010,0100)	CS	1	
Trim	(2010,0140)	CS	1	
Private Creator	(2011,00xx)	LO	1	Value is "FDMS 1.0"
Image Position Specifying Flag	(2011,xx11)	CS	1	
Image Position	(2020,0010)	US	1	
Private Creator	(50F1,00xx)	LO	1	Value is "FDMS 1.0"
Energy Subtraction Param.	(50F1,xx06)	CS	1	
Subtraction Registration Result	(50F1,xx07)	CS	1	
Energy Subtraction Param.2	(50F1,xx08)	CS	1	
Afin Conversion Coefficient	(50F1,xx09)	SL	4	
FNC Parameters	(50F1,xx0A)	ST	1	
SFT	(50F1,xx0B)	SS	1	(Only FDR-1000AWS / FDR-2000AWS / FDR-3000AWS)
Heal Effect Coefficient	(50F1,xx0C)	FL	1	
Air Suppression Version	(50F1,xx0D)	US	1	Value is "0x0002" ※When Pixel Padding Value(0028,0120) is executed, it is indispensable.
Film Output Format	(50F1,xx10)	CS	1	
Tomo Delivery Range	(50F1,xx15)	CS	1	(Only FDR-3000AWS)
Target Of Out	(50F1,xx16)	CS	1	(Only FDR-3000AWS)
Target Of Print	(50F1,xx17)	CS	1	(Only FDR-3000AWS)
TomoRawEDR	(50F1,xx1A)	SQ	1	(Only FDR-3000AWS)
Relative Light Emission Amount Sk	>(0025,xx10)	US	1	

Attribute Name	Tag	VR	VM	Notes
Image Processing Modification Flag	(50F1,xx20)	CS	1	
Scatter And Spectrum Status	(50F1,xx1B)	US	1	(Only FDR-3000AWS)
Reconstruct Algorithm	(50F1,xx1C)	SH	1	(Only FDR-3000AWS)

8.4 CODED TERMINOLOGY AND TEMPLATES

The AWS CR Storage AE do not support the use of Coded Terminology and Templates.

8.5 GRAYSCALE IMAGE CONSISTENCY

The AWS do not support DICOM Grayscale Standard Display Function.

8.6 STANDARD EXTENDED / SPECIALIZED / PRIVATE SOP CLASSES

8.6.1 Standard Extended SOP Class - Computed Radiography Image Storage

The Computed Radiography Image Storage SOP Class is extended to create a Standard Extended SOP Class by addition of standard and private attributes to the created SOP Instances as documented in section 8.1 and 8.2.

8.6.2 Standard Extended SOP Class - Digital Mammography X-Ray Image Storage

The Digital Mammography X-Ray Image Storage SOP Class is extended to create a Standard Extended SOP Class by addition of standard and private attributes to the created SOP Instances as documented in section 8.1 and 8.2.

8.6.3 Standard Extended SOP Class – Breast Tomosynthesis Image Storage

The Breast Tomosynthesis Image Storage SOP Class is extended to create a Standard Extended SOP Class by addition of standard and private attributes to the created SOP Instances as documented in section 8.1 and 8.2.

8.7 PRIVATE TRANSFER SYNTAXES

No Private Transfer Syntaxes are supported.

FUJIFILM

FUJIFILM Corporation

26-30, NISHIAZABU 2-CHOME, MINATO-KU, TOKYO 106-8620, JAPAN